

# Activity 3 Assessment

## Creating New Tessellations

### Creating New Tessellations

Identifies and describes transformations of a polygon in a tessellation

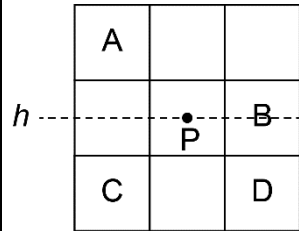

Square A is translated 2 units right, 1 unit down to its Image B.  
 Square A is reflected in a horizontal line  $h$  to its Image C.  
 Square A is rotated  $180^\circ$  about point P to its Image D.

Identifies a combination of transformations in a tessellation

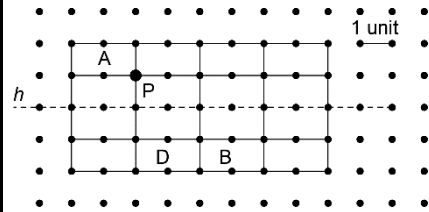

Shape A is translated 4 units right, then reflected in line  $h$  to its Image B.  
 Shape A is rotated  $180^\circ$  about point P, then translated 2 units down to its Image D.

Creates a tessellation and describes the transformation(s)

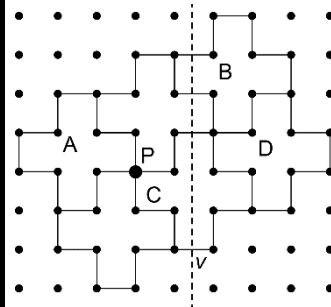

Shape A is translated 4 units right and 2 units up to its Image B.  
 Shape A is rotated  $180^\circ$  about point P to its Image C.  
 Shape A is reflected in line  $v$  to its Image D.

Creates a new shape, then tessellates it

I started with Shape A. I cut off 1 square and taped it to the opposite side. Then, I used the revised shape to create a tessellation.

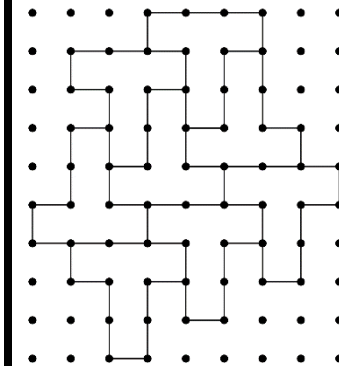

### Observations/Documentation

--	--	--	--