

PEARSON

Foundations and Pre-calculus
Mathematics 10

TEACHER RESOURCE

Chapter 2: Trigonometry

Project: Measurement *Ramp It Up!*

Chapter 2: Trigonometry

Teacher Guide Contents

Planning for Chapter 2

Chapter Overview	3
Curriculum across the Grades	5
Chapter 2 At a Glance	6
Planning for Assessment	7

Teaching Notes

2.1 The Tangent Ratio	8
2.2 Using the Tangent Ratio to Calculate Lengths	12
2.3 Math Lab: Measuring an Inaccessible Height	16
2.4 The Sine and Cosine Ratios	19
2.5 Using the Sine and Cosine Ratios to Calculate Lengths	23
2.6 Applying the Trigonometric Ratios	27
2.7 Solving Problems Involving More than One Right Triangle	31

Black Line Masters

Master 2.1a	Activate Prior Learning: Similar Triangles	35
Master 2.1b	Activate Prior Learning: Solving Equations of the Form $b = \frac{x}{a}$ and $b = \frac{a}{x}, x \neq 0$	36
Master 2.1c	Activate Prior Learning: The Pythagorean Theorem	37
Master 2.2	The Tangent Ratio	38
Master 2.3	Large Protractor	39
Master 2.4	Math Lab Recording Sheet	40
Master 2.5	Recording Sheet for Lesson 2.4 Try This	41
Master 2.6	Square Pyramid for Lesson 2.7 Think About It	42
Master 2.7	Chapter Test	43
Master 2.8	Answers	44
Master 2.9	Chapter Project: Indirect Measurement	45
Master 2.10	Chapter Rubric: Trigonometry	46
Master 2.11a	Chapter Summary: Self-Assessment and Review	47
Master 2.11b	Chapter Summary: Review Question Correlation	48

Project: Ramp It Up!

Teaching Notes	49
Project Observation Checklist	50

CD-ROM

Masters in editable Word® and pdf formats:

Masters 2.1 – 2.11
Master 2.12 Check Your Understanding 2.1
Master 2.13 Check Your Understanding 2.2
Master 2.14 Check Your Understanding 2.4
Master 2.15 Check Your Understanding 2.5
Master 2.16 Check Your Understanding 2.6
Master 2.17 Check Your Understanding 2.7

Chapter Overview

Background

In grade 8, students were introduced to the squares and square roots of whole numbers which they applied to solve problems involving the Pythagorean Theorem. In grade 9, these concepts are extended to include problems involving positive rational numbers. By the time students enter grade 10, they should be familiar with the Pythagorean Theorem and be able to apply it to determine the length of any side of a right triangle. Students should also be able to recognize perfect squares and use a calculator to determine the square root of a number that is not a perfect square after estimating its value using a benchmark.

Ratio and rate, and the solution of ratio problems are introduced in grade 8. Students solve linear equations with integer coefficients and constants in grade 8. By the end of grade 9, the coefficients and constants of these equations include rational numbers. Students should be able to use algebraic strategies to solve proportions that represent ratio problems.

Grade 9 students are introduced to the concept of similar polygons in the context of creating and interpreting scale diagrams. By examining scale diagrams, they infer the properties of similar polygons. Students apply the properties of similar triangles to solve problems and informally determine the conditions required for two triangles to be similar.

Rationale

Each trigonometric ratio is introduced using an investigative approach. Students draw right triangles and apply what they know to identify equal ratios in the similar right triangles. This mirrors the strategies students used to develop the grade 9 outcomes related to scale diagrams and similar polygons.

The tangent ratio is presented first since it relates to familiar situations involving angles of inclination. The sine and cosine ratios are introduced together after the work on the tangent ratio and its connection to the properties of similar triangles has been consolidated. In each case, the trigonometric ratio and its relationship to an acute angle is established in the introductory lesson and then this relationship is applied to determine the lengths of sides in a right triangle in a follow-up lesson.

The use of the trigonometric ratios to solve problems is scaffolded; students first solve problems for which the appropriate ratio is apparent because it is the focus of the lesson. In Lessons 2.6 and 2.7, students must determine which ratio is appropriate without having an explicit cue provided.

Big Ideas of the Chapter	Applying the Big Ideas
<p>In a right triangle,</p> <ul style="list-style-type: none"> The ratio of any two sides remains constant even if the triangle is enlarged or reduced. 	<ul style="list-style-type: none"> The size of the triangle does not affect the value of any trigonometric ratio of an acute angle in the triangle.
<ul style="list-style-type: none"> You can use the ratio of the lengths of two sides to determine the measure of one of the acute angles. 	<ul style="list-style-type: none"> If the tangent ratio, sine ratio, or cosine ratio of an angle is known, the related inverse operation — \tan^{-1}, \sin^{-1}, or \cos^{-1} — on a scientific calculator can be used to determine the measure of the angle.
<ul style="list-style-type: none"> You can use the length of one side and the measure of an acute angle to determine the length of another side of the triangle. 	<ul style="list-style-type: none"> You can use the definition of the tangent ratio, sine ratio, or cosine ratio to create an equation. You can then solve this equation to determine the unknown side length.
<ul style="list-style-type: none"> You can use the primary trigonometric ratios to solve problems that can be represented using right triangles. 	<ul style="list-style-type: none"> You can solve problems that involve more than one right triangle by applying the trigonometric ratios to one triangle at a time.

Curriculum across the Grades

WNCP Grade 8	WNCP Grade 9	WNCP Foundations of Mathematics and Pre-calculus 10
<p>Number N1 Demonstrate an understanding of perfect square and square root, concretely, pictorially, and symbolically (limited to whole numbers). N2 Determine the approximate square root of numbers that are not perfect squares (limited to whole numbers). N4 Demonstrate an understanding of ratio and rate. N5 Solve problems that involve rates, ratios and proportional reasoning.</p> <p>Patterns and Relations (Variables and Equations) PR2 Model and solve problems using linear equations of the form: • $ax = b$ • $\frac{x}{a} = b, a \neq 0$ concretely, pictorially, and symbolically, where a and b are integers.</p> <p>Shape and Space (Measurement) SS1 Develop and apply the Pythagorean Theorem to solve problems.</p>	<p>Number N5 Determine the square root of positive rational numbers that are perfect squares. N6 Determine an approximate square root of positive rational numbers that are non-perfect squares.</p> <p>Patterns and Relations (Variables and Equations) PR3 Model and solve problems using linear equations of the form: • $\frac{x}{a} = b, a \neq 0$ • $\frac{a}{x} = b, x \neq 0$ where a and b are rational numbers.</p> <p>Shape and Space (3-D Objects and 2-D Shapes) SS3 Demonstrate an understanding of similarity of polygons. SS4 Draw and interpret scale diagrams of 2-D shapes.</p>	<p>Measurement M4 Develop and apply the primary trigonometric ratios (sine, cosine, tangent) to solve problems that involve right triangles. [C, CN, PS, R, T, V]</p> <p>4.1 Explain the relationships between similar right triangles and the definitions of the primary trigonometric ratios. 4.2 Identify the hypotenuse of a right triangle and the opposite and adjacent sides for a given acute angle in the triangle. 4.3 Solve right triangles, with or without technology. 4.4 Solve a problem that involves one or more right triangles by applying the primary trigonometric ratios or the Pythagorean Theorem. 4.5 Solve a problem that involves indirect and direct measurement, using the trigonometric ratios, the Pythagorean Theorem and measurement instruments such as a clinometer or metre stick.</p>

Chapter 2 At a Glance

Lesson	Timing (min)	Materials and Resources	Program Support
Lesson 2.1 The Tangent Ratio, page 8 Develop the tangent ratio and relate it to the angle of inclination of a line segment.	75	<ul style="list-style-type: none"> • protractors • rulers • grid paper 	Master 2.1a Master 2.2
Lesson 2.2 Using the Tangent Ratio to Calculate Lengths, page 12 Apply the tangent ratio to calculate lengths.	60 - 75	<ul style="list-style-type: none"> • protractors • rulers • scientific calculators 	Master 2.1b Master 2.1c
Lesson 2.3 Math Lab: Measuring an Inaccessible Height, page 16 Determine a height that cannot be measured directly.	75 - 90	<ul style="list-style-type: none"> • large 180° protractor • scissors • measuring tape or 2 metre sticks • heavy cardboard • drinking straws • glue • adhesive tape • needles and thread • small metal washers or weights • grid paper • scientific calculators 	Master 2.3 Master 2.4
Lesson 2.4 The Sine and Cosine Ratios, page 19 Develop and apply the sine and cosine ratios to determine angle measures.	75	<ul style="list-style-type: none"> • protractors • rulers • grid paper • scientific calculators 	Master 2.5
Lesson 2.5 Using the Sine and Cosine Ratios to Calculate Lengths, page 23 Use the sine and cosine ratios to determine lengths indirectly.	60 - 75	<ul style="list-style-type: none"> • scientific calculators 	
Lesson 2.6 Applying the Trigonometric Ratios, page 27 Use a primary trigonometric ratio to solve a problem modelled by a right triangle.	60 - 75	<ul style="list-style-type: none"> • scientific calculators 	
Lesson 2.7 Solving Problems Involving More than One Right Triangle, page 31 Use trigonometry to solve problems modelled by more than one right triangle.	60 - 75	<ul style="list-style-type: none"> • scientific calculators 	Master 2.6

Planning for Assessment

Purpose	Tools and Process	Recording and Reporting
Assessment for Learning	<i>Chapter Launch</i> <i>Try This or Think About It</i> Assessing Understanding: Observe and Listen <i>Check Your Understanding</i> <i>Exercises:</i> selected questions <i>Checkpoint: Assess Your Understanding</i> Question: conference; scaffold problems throughout the chapter	Master 2.10 Chapter Rubric: Trigonometry PM 1 Inquiry Process Checklist PM 11 Observation Record 1 PM 12 Observation Record 2 PM 13 Conference Prompts PM 14 Work Sample Records
Assessment as Learning	<i>Reflect</i> <i>Check Your Understanding</i> <i>Exercises:</i> selected questions <i>Checkpoint: Assess Your Understanding</i> Prompt student’s self-assessment Review student work; provide feedback; scaffold as needed; select key pieces	Master 2.11a Chapter Summary: Self-Assessment and Review Master 2.11b Chapter Summary: Review Question Correlation PM 2 Self-Assessment PM 3 Self-Assessment: Problem Solving PM 4 Think Mathematics PM 5 A Good Place for Learning PM 6 Before I Start PM 7 Check Your Understanding PM 8 Reflecting on My Work
Assessment of Learning	<i>Review</i> <i>Practice Test</i> <i>Chapter Test</i> <i>Chapter Project</i> Review assessment records; add chapter results to ongoing records	Master 2.10 Chapter Rubric: Trigonometry Master 2.7 Chapter Test Master 2.9 Chapter Project: Indirect Measurement
Learning Skills/ Mathematical Dispositions	Observe and record throughout the chapter	PM 9 Learning Skills Checklist PM 10 Mathematical Dispositions and Learning Skills

Program Masters (PM) are in the *Program Overview* module.

2.1

The Tangent Ratio

Lesson Organizer

60 - 75 min

Key Math Learnings

In a right triangle, the ratio of the side opposite an acute angle to the side adjacent to it depends only on the measure of that angle.

Curriculum Focus

Develop the tangent ratio and relate it to the angle of inclination of a line segment.

SO	AI
M4	4.1, 4.2, 4.4

Processes

C, CN, PS, R, T, V

Teacher Materials

- overhead transparency of grid paper

Student Materials

- ruler
- protractor
- grid paper
- scientific calculator
- Master 2.1a (optional)
- Master 2.2 (optional)

Vocabulary

angle of inclination, side opposite an angle, side adjacent to an angle, tangent ratio

Make Connections, SB page 70

The chapter extends the properties of similar triangles studied in grade 9.

Students should realize that the angles in a diagram do not change when the scale of the diagram changes.

Students should be able to construct a triangle similar to a given right triangle, identify pairs of corresponding sides and angles, and state the ratio of the corresponding sides. You may wish to use Master 2.1a to activate prior learning about similar triangles.

The solar panel context offers an opportunity for students to relate math to environmental issues such as global warming and non-polluting or renewable energy sources. You could use a flashlight (to model the sun) and cardboard (to model the solar panel) to show that the exposure to the sun varies as the angle of inclination of a panel changes, and the exposure also varies as the angle of the sun's rays changes.

Construct Understanding, SB page 71

Assessing Understanding: Observe and Listen

As students work, ask questions such as:

- How do you know that the triangles you drew are right triangles? (*I used the grid lines to ensure each triangle has a 90° angle.*)
- How do you know that the triangles you are drawing will be similar to the original triangle? (*I used the same scale factor to draw each side of my new triangle. The triangles have corresponding angles equal.*)
- What do you notice about the value of the ratio $\frac{CB}{BA}$ in each triangle? (*The decimal values are the same.*)

DI Cultural Perspectives

As an alternative to each student drawing a right triangle independently, have students discuss how right triangles may be similar. Students then take turns to draw a right triangle, ensuring that each triangle has characteristics that make it similar to the preceding triangle drawn. Through collaborative learning and its related discussion, students should gain confidence in their abilities and in their dialogues with their peers; this is the foundation concept of sharing circles and the consensus model.

DI Identifying Common Difficulties: Possible Intervention

The student has difficulty drawing one triangle similar to another.

- Draw line segments along the edges of 1 and 2 squares of the grid paper. Ask the student what scale factor is applied to the shorter

segment to get the longer one. (2) Invite the student to draw a triangle similar to the original triangle using scale factor 2. Ask, “How could you draw a triangle with scale factor 3? 4?” (*Each leg would be 3 or 4 times as long as the original leg. I could count squares vertically and horizontally to do this.*)

DI Extending Thinking

Ask students to visualize right $\triangle ABC$ when $\frac{CB}{BA} = 1$. Ask, “What kind of triangle must it be?” (*An isosceles right triangle with acute angles of 45°*)

Debrief Try This: Assessment for Learning

Invite students to record their measurements in a chart, such as Master 2.2, on the overhead projector or board. Ask questions such as:

- What do you notice about the value of the ratio $\frac{CB}{BA}$ for each $\angle A$? (*All the values are equal.*)

- What do you think determines the value of this ratio? (*The measure of $\angle A$*)

Students should recognize that, in a right $\triangle ABC$ with $\angle B = 90^\circ$:

- For each value of $\angle A$, the value of $\frac{CB}{BA}$ is constant.
- Different measures of $\angle A$ produce different values for $\frac{CB}{BA}$.
- The value of the ratio depends only on the measure of $\angle A$, not on the size of the triangle.

Assessment for Learning

What to look and listen for:

- Students can draw a right triangle and identify the hypotenuse, the side opposite a given angle, and the side adjacent to that angle.
- Students can calculate the tangent of an acute angle in a given right triangle.
- Students can determine the measure of an acute angle given the tangent of that angle.
- Students can use the tangent ratio to solve problems involving angles.

Ensure students recognize that, for a given acute $\angle A$ in a right triangle, the ratio of the opposite side to the adjacent side is constant, and the definition of the tangent of $\angle A$ makes sense. Ask questions such as:

- If I change the position of the right triangle, what happens to the tangent ratio? (*Nothing, the tangent ratio does not depend on where the triangle is; it depends only on the size of the angle.*)
- Could I use any $\triangle ABC$ to determine the value of $\tan A$? (*No, the triangle must be a right triangle. In a non-right triangle, any acute angle has 2 sides that could be labelled “adjacent.”*)

Technology Note: This is the first occasion students have used the trigonometric operations on a scientific calculator. Degree mode is usually the default setting. Have students enter $\tan 45$ to check the setting. If the answer is not 1, they should consult their Users Manual to change the mode. Ensure students know how to determine the inverse tangent.

In Example 4, the calculator display illustrates how to determine the inverse tangent by using the number in the calculator display directly rather than re-inputting it; that is, use \tan^{-1} Ans.

DI Identifying Common Difficulties: Possible Intervention

The student has difficulty identifying the opposite and adjacent sides for the angle under consideration.

- Students can identify the hypotenuse as the longest side, then remember that *adjacent* means “next to,” so the side other than the hypotenuse that is next to the angle is the adjacent side.

The student uses incorrect measures when calculating the tangent ratio.

- Have students sketch the diagram, mark the angle then draw arrows from the vertex to the hypotenuse, adjacent side, and opposite side.

DI Extending Thinking

Use the question prompts in the screened boxes of the Student Book.

SB p. 72: As the size of $\angle A$ increases, what happens to $\tan A$?	<i>Tan A increases as $\angle A$ approaches 90°. Since the adjacent side gets closer to 0, the denominator of the fraction $\frac{\text{opposite}}{\text{adjacent}}$ approaches 0.</i>
SB p. 72, Example 1: How are the values of $\tan D$ and $\tan F$ related? Explain why this relation will always be true for the acute angles in a right triangle.	<i>Tan D is the reciprocal of $\tan F$. This makes sense since the side opposite $\angle D$ is adjacent to $\angle F$, and vice versa; so the numerator and denominator switch.</i>
SB p. 73, Example 2: What other strategy could you use to determine $\angle J$?	<i>I could calculate: $90^\circ - \angle G = 90^\circ - 38.7^\circ = 51.3^\circ$</i>
SB p. 74, Example 4: Suppose you used $PQ \doteq 9.2$ instead of $PQ = \sqrt{84}$. How could this affect the calculated measure of $\angle R$?	<i>When I round $\sqrt{84}$, I lose some accuracy. $\tan R$ would be $\frac{9.2}{4}$, which gives $\angle R = 66.5014\dots^\circ$. When I round this measure to the nearest degree, it is 67°, so the answer would be incorrect.</i>

DI Cultural Perspectives

Renewable energy sources, as described in *Make Connections* and referenced in *Example 3*, relate directly to stewardship of the earth and should be of interest to most students.

Assessing Understanding: Discuss the Ideas, SB page 74

Sample Responses

1. *The tangent of an angle is the ratio $\frac{\text{opposite}}{\text{adjacent}}$ formed using the lengths of the legs of a right triangle. When I draw another right triangle with the same acute angle, the triangles are similar and the ratio becomes $\frac{\text{opposite} \times \text{scale factor}}{\text{adjacent} \times \text{scale factor}}$. This ratio is equivalent to the previous ratio.*

2. The tangent of an angle is the ratio of the opposite side to the adjacent side. When I know the value of $\tan A$, I can use the \tan^{-1} (or invtan) to determine the measure of $\angle A$. Since the sum of the angles in any triangle is 180° , the sum of the acute angles in a right triangle is 90° . So, the measure of the other acute angle is $90^\circ - \angle A$.

DI Cultural Perspectives

You may wish to reverse the order of the questions in Discuss the Ideas – to move from what we can do and how we do it to why we may not be able to do something. Skill and knowledge transfers from what we know to applications that involve what we do not yet know. Discussion may clarify shared thoughts and concepts; it follows from what we believe we know to what we are learning. This may be particularly helpful for First Nations, Métis, and Inuit students.

Exercises, SB page 75

Have grid paper available. Remind students that a diagram showing all the given information should be the first step in the solution of any problem. Their sketches need not be accurate, but reasonable representations of the given situation can help them decide on a strategy.

DI Cultural Perspectives

The Pythagorean spiral shown in question 23 may seem an abstract concept to many students. You may wish to tell your students that it is the basis of the design model used to build the high school in the Ermineskin Cree Nation community, located in the Hobbema area of Alberta.

Assessment of Learning – selected questions

AI	4.1	4.2	4.4
Question number	9	6	11

Sample Response: Reflect, SB page 77

In any right triangle, the tangent ratio of an acute angle is the ratio of the length of the side opposite the angle to the length of the side adjacent to the angle. I can calculate this ratio as a decimal, then use the \tan^{-1} key on my calculator to determine the measure of the angle in degrees.

Looking Ahead

In Lesson 2.2, students will use their knowledge of the tangent ratio and the Pythagorean Theorem to calculate the lengths of the sides of a right triangle.

Using the Tangent Ratio to Calculate Lengths

Lesson Organizer

60 - 75 min

Key Math Learnings

Because the tangent ratio is constant for a given angle in a right triangle, it can be applied to calculate the length of a side of any right triangle, even when we cannot measure the length directly.

Curriculum Focus

Apply the tangent ratio to calculate lengths.

SO	AI
M4	4.2, 4.4

Processes

C, CN, PS, R, T, V

Teacher Materials

- demonstration ruler
- demonstration protractor

Student Materials

- ruler
- protractor
- scientific calculator
- Master 2.1b (optional)
- Master 2.1c (optional)

Vocabulary

direct measurement,
indirect measurement

Make Connections, SB page 78

Students' prior experience with constructing triangles can help to reinforce their understanding of tangent as a constant ratio: given limited information about a right triangle (in this case, the length of one side and the measure of one acute angle), they have sufficient information to construct a unique triangle.

Encourage students to think about various ways to determine unknown measures in the triangle. Students who relate the opening photograph to the work they did in Lesson 2.1 may realize that they can use the tangent ratio to calculate the length of the other leg of the triangle. They can then use the Pythagorean Theorem to calculate the length of the hypotenuse.

Construct Understanding, SB page 78

Assessing Understanding: Observe and Listen

As students work, prompt them to visualize the problem, and to reason mathematically, with questions such as:

- How can you represent the problem? (*I can't construct the triangle because 46.1 cm is too long. I could draw a scale diagram. I can make a sketch.*)
- What strategy can you use to determine the length of RQ? (*I can measure my scale diagram, but my answer is probably not correct to the nearest tenth of a centimetre. I could use the tangent ratio to write an equation that involves RQ. Then I could solve the equation for RQ.*)

DI Identifying Common Difficulties: Possible Intervention

The student uses direct measurement.

- Allow students to use a scale diagram for an estimated answer. Suggest a simple scale, such as 1 cm to represent 10 cm, to simplify the work.
- Some students may benefit from creating a full-scale diagram, using the board, a metre stick, and a large protractor.

Ask, "How can you use what you learned in Lesson 2.1 to check your answer?" (*I could use the length I get for RQ by measuring and the given length for PQ to write the tangent ratio for $\angle P$. I could calculate this ratio and check that it is equal to $\tan 34.5^\circ$.)*

"How could you use the tangent ratio to calculate RQ? (I could write this equation: $\tan 34.5^\circ = \frac{RQ}{46.1}$, then solve the equation to get RQ is approximately 31.7 cm.)

Assessment for Learning

What to look and listen for:

- Students can draw and label the right triangle described in a given problem.
- Students can set up an equation involving the tangent ratio, then solve the equation to determine the measure of a leg of a right triangle.
- Students can use the tangent ratio to solve problems involving an unknown side length of a right triangle.

DI Extending Thinking

Ask students to identify other measurements they can determine. They may suggest:

- Determine the measure of $\angle R$ as $180^\circ - (90^\circ + 34.5^\circ)$; or, since $\triangle PQR$ is a right triangle, $\angle R = 90^\circ - 34.5^\circ = 55.5^\circ$
- Determine the length of the hypotenuse using the Pythagorean Theorem; PR is approximately 55.9 cm.

Debrief Think About It: Assessment for Learning

As students share their strategies for determining the length of RQ, introduce the idea of indirect measurement as a strategy that can be applied in many applications, regardless of scale or accessibility. Ask:

- What problems are there with using a scale diagram? (*It was time-consuming to create an accurate scale diagram. It's hard to measure an angle to the nearest half of a degree. We rounded the length 46.1 cm to 46 cm to be able to draw it on the scale diagram.*)
- In what situations might it be impossible to use direct measurement to determine a length? (*If I wanted to find the height of a totem pole, I wouldn't be able to measure it directly.*)

On the board, construct $\triangle PQR$ from *Think About It*, to demonstrate that an accurate construction takes time, and to allow students to verify the accuracy of the calculated result.

Highlight that trigonometry provides tools for calculating measurements when it is not possible to measure directly or when accuracy is required. Part of the solution to a problem might be to identify a relevant right triangle for which you know the measure of one acute angle and the length of a leg.

As you work through the *Examples*, or have students work on the *Check Your Understanding* problems, model the importance of a diagram to help interpret a problem. Reinforce how the opposite and adjacent sides are determined relative to the known angle in the problem.

Students will solve equations of the form $b = \frac{x}{a}$ and $b = \frac{a}{x}$, $x \neq 0$. If your students need to review the strategies to solve these types of equations, have them complete Master 2.1b. When you model solutions to these equations, highlight the principle of maintaining equality.

Students may use the Pythagorean Theorem in this lesson. You may wish to use Master 2.1c to activate their prior learning about this concept.

Technology Note: Ensure students' calculators are set to degree mode. Have students enter the calculations as you demonstrate the solutions to problems. As students corroborate your result with their own, they will identify whether they need to correct their calculator settings, and learn the correct keystrokes.

DI Identifying Common Difficulties: Possible Intervention

The student has difficulty writing an equation to determine a length of a leg.

- Have the student list the given information, then use it to label a sketch of a triangle. Suggest the student check off each piece of information while labelling the diagram. Then have the student label the sides “opposite” and “adjacent to” the known angle. Provide this prompt for placing known

values in the equation: $\tan \text{ ______ } = \frac{\text{opposite}}{\text{adjacent}}$.

DI Extending Thinking

Use the question prompts in the screened boxes of the Student Book.

SB p. 79, Example 1: How can you determine the length of the hypotenuse in $\triangle ABC$?	<i>When I know that the measure of the second leg is about 5.774 cm, I can use the Pythagorean Theorem to calculate the length of the hypotenuse, in centimetres, as: $\sqrt{10^2 + 5.7735\dots^2} \doteq 11.5$</i>
SB p. 80, Example 2, Method 1: What is the advantage of solving the equation for EF before calculating $\tan 20^\circ$?	<i>By solving the equation first, I can enter $\tan 20^\circ$ directly in my calculator instead of entering its decimal value.</i>
SB p. 80, Example 2, Method 2: Which method to determine EF do you think is easier? Why? How could you determine the length of DF?	<i>I prefer Method 2 since using $\angle D$ means I get an equation where the length I am calculating is in the numerator. I find this type of equation easier to solve. I would use the Pythagorean Theorem to calculate DF: $\sqrt{9.6161\dots^2 + 3.5^2} \doteq 10.2$</i>
SB p. 81, Example 3: Why can we draw a right triangle to represent the problem?	<i>The searchlight beam is vertical and the ground is horizontal, so the angle between the beam and the ground is 90°.</i>

Assess Understanding: Discuss the Ideas, SB page 81

Sample Responses

1. *To determine the length of a leg in a right triangle, I write an equation for the tangent ratio for the given angle. I make sure the equation includes the leg I am trying to find. I solve this equation to determine the length of the leg.*
2. *The lengths of the two legs of a right triangle are enough to calculate the hypotenuse, because I can use the Pythagorean Theorem when I know the lengths of 2 of the 3 sides.*

Exercises, SB page 82

Assessment of Learning – selected questions

AI	4.2	4.4
Question number	9	13

Sample Response: Reflect, SB page 83

I can only use the tangent ratio to determine the length of a leg in a right triangle, to be able to do this, I need to know the measure of one angle and the length of the other leg.

If the leg I know is opposite the angle I know, then I write and solve an equation of this form:

$$\text{Tangent of the angle I know} = \frac{\text{Length of side I know}}{\text{Length of side I want to determine}}$$

If the leg I know is adjacent to the angle I know, then I write and solve an equation of this form:

$$\text{Tangent of the angle I know} = \frac{\text{Length of side I want to determine}}{\text{Length of side I know}}$$

Looking Ahead

In Lesson 2.3, students create and use clinometers to calculate measures indirectly. The students will use the tangent ratio and the Pythagorean Theorem.

Before you teach this lesson, make a demonstration clinometer so students will know what their finished clinometers should look like.

2.3

MATH LAB: Measuring an Inaccessible Height

Lesson Organizer

75 - 90 min

Key Math Learnings

A clinometer, a measuring tape, and the tangent ratio can be used to solve a problem that involves indirect measurement.

Curriculum Focus

Determine a height that cannot be measured directly.

SO	AI
M4	4.5

Processes

C, CN, PS, R, T, V

Teacher Materials

- demonstration clinometer
- ruler
- protractor
- overhead transparency of grid paper

Student Materials

- scissors
- measuring tape or 2 metre sticks
- cardboard
- drinking straw
- glue
- adhesive tape
- needle and thread
- small washer or weight
- grid paper
- clinometer (*optional*)
- Master 2.3
- Master 2.4 (*optional*)

Make Connections, SB page 84

A clinometer is used by tree farmers to measure heights of trees. The device is used to measure the angle between a reference line and the line of sight to an object, as accurately as possible. When the angle measurement is known, it can be used along with a length measurement and some trigonometry to determine an inaccessible length.

In this example, the tangent of the measured angle is equal to the ratio of the height of the tree to the horizontal distance from the clinometer to the tree.

This activity is designed to provide students with the opportunity to perform this kind of task and to get a sense of how practical mathematics is. Students will use the tangent ratio to calculate the length of a leg of a right triangle that represents the height of an inaccessible object. If the weather or school situation is unsuitable for students to conduct their measurement outdoors, have students determine the height of the gym or a hall in the school.

Construct Understanding, SB page 84

It may take students up to 30 min to make a clinometer. They could construct the clinometers in one period and use another period for the data collection and calculations. The remainder of the first period could be used to discuss the graphic organizer in Checkpoint 1 and for students to work through the Assess Your Understanding questions there. This will help consolidate students' use of the tangent ratio to solve measurement problems before they have to apply it in this lab. Alternatively, students could make their clinometers and take the measurements in one period, then complete the calculations and Assess Your Understanding questions in Checkpoint 1 in the second period.

Commercially produced clinometers are available, and if you have access to a set of these, students should omit Step A.

Assign several pairs of students to measure the same object from different locations. This should provide examples of the effects of terrain on accuracy of measurement.

Within each pair, students can take turns using each other's clinometer, generating four angle measures for each sighting. They can then determine the most accurate angle measure to use in their calculations.

Suggest that students try for the greatest precision possible with their measuring instruments; that is, they record the angle measures to the nearest degree and lengths to the nearest centimetre.

Encourage students to estimate the height of their object before they begin their computation. This will allow them to assess the reasonableness of their calculated answers and to check for incorrect calculator entries or settings.

Assessing Understanding: Observe and Listen

As students work, ask questions such as:

- How did you measure the vertical distance from the ground to your partner's eye? (*My partner stood against the wall and I used a tape measure to measure the distance of her eyes from the floor.*)
- How did you use the angle you measured on your clinometer in the right triangle you drew for the problem? (*The measured angle is 55.0° . The angle between the horizontal and the string is 90° . I know the angle on a straight line is 180° . So, in my triangle, the angle between the horizontal and my line of sight is $180^\circ - 90^\circ - 55.0^\circ = 35.0^\circ$.)*)

Assessment for Learning

What to look and listen for:

- Students can read the angle measure from the clinometer.
- Students can calculate the angle of inclination of the straw as $(90^\circ - \text{the measured angle on the protractor})$.
- Students can sketch and label a triangle to represent the height of an inaccessible object.
- Students can use their measurements and the tangent ratio to determine an inaccessible height.

DI Identifying Common Difficulties: Possible Intervention

The student has difficulty understanding how the angle measured on the clinometer relates to the angle of inclination of the straw.

- Orientate a copy of Master 2.3 to match the orientation of the clinometer. Have the student draw the vertical line for the thread and the line for the horizontal. This produces 3 angles at the centre of the baseline of the protractor. Have the student label each angle with its measure. The student should see that the required angle is 90° minus the angle on the clinometer.

The student has difficulty recording the data and transferring it to a sketch.

- Provide a copy of Master 2.4 for the student to complete.

DI Extending Thinking

Ask students how they might solve a similar problem about determining the height of an inaccessible object if they were standing on top of a hill looking down on the object or if they were standing in a valley looking up at the object.

Debrief Try This: Assessment for Learning

Invite a pair of students to record their labelled sketch on the overhead projector or board. Ask questions such as:

- How do you think the students who made this sketch calculated the height of their object? (*They used the tangent ratio to write an equation: the tangent of the angle of inclination is equal to the ratio of the height of the object above eye level to the horizontal distance. The students solved the equation to get the height of the object above eye level, then added the height of the eyes above the ground. The answer is the height of the object.*)
- How did the height of your eyes affect your measurements? (*The height of my eyes didn't make any difference to the equation we used to find the height of the part of the object that we modelled with a right triangle. Only after we found this height did we have to add the height of the eyes.*)

DI Extending Thinking

Use the question prompts in the screened boxes of the Student Book.

SB p. 86: How does the acute angle between the thread and the straw relate to the angle of inclination of the straw?

The angle of inclination is equal to 90° minus the angle between the thread and the straw.

SB p. 86: What other strategy could you use to determine the height of the object?

I could draw an accurate scale drawing, because I know the angle of inclination and the horizontal distance. Then I could measure the height on the scale diagram and use the scale to estimate the actual height.

If the sun was shining, I could use similar triangles and the lengths of the shadows of the object and a metre stick held vertically. I would solve the equation:

$$\frac{\text{height of object}}{\text{length of its shadow}} = \frac{\text{height of metre stick}}{\text{length of its shadow}}$$

DI Cultural Perspective

Many First Nations people are involved in the forestry industry. You could arrange to have a spokesperson from the industry talk to your students about how the height of a tree is measured, and why surveys of forests are important.

Assess Your Understanding, SB page 86

Assessment of Learning – selected questions

AI	4.5
Question number	2

Looking Ahead

Tell the students to keep their straw clinometers for work in a later Review exercise.

In Lesson 2.4, students extend their knowledge of similar right triangles to write and use ratios for the sine and cosine of an angle.

2.4

The Sine and Cosine Ratios

Lesson Organizer

75 min

Key Math Learnings

In a right triangle, there are two trigonometric ratios that relate the opposite side to the hypotenuse and the adjacent side to the hypotenuse.

Curriculum Focus

Develop and apply the sine and cosine ratios to determine angle measures.

SO	AI
M4	4.1, 4.2, 4.4

Processes

C, CN, PS, R, T, V

Teacher Materials

- overhead transparency of grid paper

Student Materials

- ruler
- protractor
- grid paper
- scientific calculator
- Master 2.5 (optional)

Vocabulary

sine ratio,
cosine ratio,
primary trigonometric ratios,
trigonometry,
angle of elevation

Make Connections, SB page 89

Ask if any students have travelled on the railway between Field and Hector, or if they have travelled along the TransCanada highway and seen the train as described in the Student text.

Discuss possible strategies for determining the measure of the angle of inclination. Students may suggest:

- drawing a scale diagram (but the relative lengths of 297 m and 6600 m may make it difficult to choose a suitable scale), or
- using the Pythagorean Theorem to determine the length of the adjacent side, then use the tangent ratio.

Have student volunteers demonstrate each method on the overhead projector or the board.

Discuss why the tangent ratio solution requires two steps to determine the angle. Since the hypotenuse is not involved in the tangent ratio, we had to determine the length of the adjacent side before calculating the tangent ratio. Explain that this lesson introduces two new ratios that involve the hypotenuse. Students will be able to use these ratios to determine the measure of an acute angle when the length of the hypotenuse is given.

Construct Understanding, SB page 90

Ask a student volunteer to explain why the tangent ratio depends only on the measure of the angle and not on the size of the triangle. Have students justify why they think the two ratios that relate the lengths of a leg and the hypotenuse will also depend only on the measure of the angle. If students discuss this before they conduct the activity, they can later explain whether their observations confirmed this.

Assessing Understanding: Observe and Listen

As students work, ask questions such as:

- Angle A is common to each triangle. How are the other acute angles in each triangle related? (*Since each triangle contains $\angle A$ and one angle of 90° , the third angle in each triangle is $180^\circ - 90^\circ - \angle A$. So, the third angles in the triangles are equal; that is, $\angle B = \angle D = \angle F = \angle H$.)*)
- How are the triangles related? (*Since the triangles have corresponding angles equal, the triangles are similar; that is, $\triangle ABC \sim \triangle ADE \sim \triangle AFG \sim \triangle AHJ$.*)

Assessment for Learning

What to look and listen for:

- Students can identify the hypotenuse in a right triangle, the side opposite a given acute angle, and the side adjacent to that angle.
- Students can write the ratios of $\frac{\text{opposite}}{\text{hypotenuse}}$ and $\frac{\text{adjacent}}{\text{hypotenuse}}$.
- Students can determine the measure of an acute angle given the sine or cosine of that angle.
- Students can use the sine and cosine ratios to solve problems involving angle measures in a right triangle.

DI Identifying Common Difficulties: Possible Intervention

The student has difficulty determining the lengths of the adjacent side and the hypotenuse for each triangle after the first triangle.

- On a copy of the nested triangles, have the student add the two measures to determine the length of the adjacent side AE ($4 + 4 = 8$), then write the measure, in colour, along that side. The student repeats a similar process for the hypotenuse, then for the other sides of the larger triangles.

The student has difficulty drawing another set of nested triangles.

- Have the student choose two different measures for the legs of the first triangle, such as 5 units horizontally and 6 units vertically, then count squares to draw these legs on grid paper. After the student has drawn the first triangle on grid paper, have him count squares (5 more horizontally and 6 more vertically) then draw the next triangle. The student can repeat this process to draw the last two nested triangles.

DI Extending Thinking

Ask students:

- What would the ratios be if $\triangle ABC$ was an isosceles right triangle? (*I drew an isosceles right triangle with legs 1 unit. Since the legs are equal, the ratios will also be equal. I used the Pythagorean Theorem to calculate the hypotenuse as $\sqrt{2}$; so each ratio is $\frac{1}{\sqrt{2}}$, or about 0.7.*)

Debrief Try This: Assessment for Learning

Invite a pair of students to record their measurements on the overhead projector or board. Ask questions such as:

- For each set of triangles, how do the ratios compare? (*All the ratios of $\frac{\text{side opposite } \angle A}{\text{hypotenuse}}$ were equal, and all the ratios of $\frac{\text{side adjacent to } \angle A}{\text{hypotenuse}}$ were equal.*)
- Why are the ratios equal? (*Since the triangles are similar, the corresponding sides are proportional. So, the ratio of the adjacent side to the hypotenuse is the same in each triangle. And, the ratio of the adjacent side to the hypotenuse is the same in each triangle.*)
- What does the value of each ratio depend on? (*It depends only on the measure of the angle, and does not depend on the size of the triangle.*)

Students should recognize that, in a right $\triangle ABC$ with $\angle C = 90^\circ$:

- For each value of $\angle A$, the value of $\frac{CB}{BA}$ is constant and the value of $\frac{CA}{BA}$ is constant.
- Different measures of $\angle A$ produce different values for $\frac{CB}{BA}$ and for $\frac{CA}{BA}$.

Ask questions such as:

- In a right triangle, if $\sin A = 0.6$, how are the sides of the triangle related? (*The opposite side is 0.6 times as long as the hypotenuse.*)

- In a right triangle, if $\cos A = 0.6$, how are the sides of the triangle related? (*The adjacent side is 0.6 times as long as the hypotenuse.*)

Technology Note: Ensure students know how to use their scientific calculators to determine the sine and cosine of an angle in degrees, and to determine the measure of the angle in degrees when the sine or cosine of the angle is known.

The angle of elevation is introduced in *Example 3*. Have students illustrate their understanding of this concept by suggesting situations in the classroom, such as the angle of elevation of a point on the ceiling.

DI Identifying Common Difficulties: Possible Intervention

The student confuses the ratios for sine and cosine.

- Have the student decide on a strategy for understanding and differentiating between these ratios.

DI Extending Thinking

Use the question prompts in the screened boxes of the Student Book.

<p>SB p. 91: What happens to $\sin A$ as $\angle A$ gets closer to 0°?</p> <p>What happens to $\cos A$ as $\angle A$ gets closer to 0°?</p>	<p><i>As $\angle A$ approaches 0°, the opposite side approaches 0, so the ratio $\frac{\text{opposite}}{\text{hypotenuse}}$, which is $\sin A$, also approaches 0.</i></p> <p><i>As $\angle A$ approaches 0°, the length of the adjacent side approaches the length of the hypotenuse, so the ratio $\frac{\text{adjacent}}{\text{hypotenuse}}$, which is $\cos A$, approaches 1.</i></p>
<p>SB p. 92, Example 1: Determine $\sin F$ and $\cos F$. How are these values related to $\sin D$ and $\cos D$?</p>	<p>$\sin F = \frac{12}{13} \doteq 0.92$ and</p> <p>$\cos F = \frac{5}{13} \doteq 0.38$; so,</p> <p>$\sin F = \cos D$ and $\cos F = \sin D$.</p>
<p>SB p. 93, Example 2: How are $\cos G$ and $\sin H$ related? Explain why this relationship occurs.</p>	<p>$\cos G = \frac{6}{14}$ and $\sin H = \frac{6}{14}$; so</p> <p>$\cos G = \sin H$; since the side opposite $\angle H$ is the side adjacent to $\angle G$, then $\sin H = \cos G$.</p>

Assessing Understanding: Discuss the Ideas, SB page 94

Sample Responses

1. *I can use the sine ratio when I know the lengths of the hypotenuse and the side opposite the angle. I can use the cosine ratio when I know the lengths of the hypotenuse and the side adjacent to the angle.*

2. The sketch shows all the information I am given and makes it easy to see which side is opposite the angle I am interested in and which is adjacent to the angle.
3. The hypotenuse is the longest side in a right triangle. So, the denominator in the fraction form of the sine or cosine ratio of an acute angle will always be greater than the numerator, which means the fraction will be less than 1.

Exercises, SB page 95

Remind students that a diagram showing all the given information should be the first step in the solution of any problem. Their sketches need not be drawn to scale, but reasonable representations of the given situation can help them decide on a strategy.

Assessment of Learning – selected questions

AI	4.1	4.2	4.4
Question number	9	4	13

Sample Response: Reflect, SB page 96

To determine the measure of an acute angle in a right triangle, I would use the sine ratio when I know the lengths of the opposite side and the hypotenuse; and I would use the cosine ratio when I know the lengths of the adjacent side and the hypotenuse. I would use the tangent ratio when I know the lengths of the legs.

For example, in $\triangle ABC$, I would use the sine ratio to determine the measure of $\angle C$ and the cosine ratio to determine the measure of $\angle A$. In $\triangle PQR$, I would use the tangent ratio to determine the measure of $\angle P$ or $\angle R$.

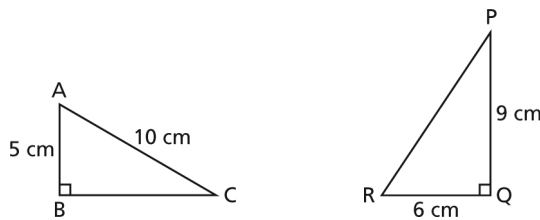

Looking Ahead

In Lesson 2.5, students will apply the sine and cosine ratios to determine the length of the leg or hypotenuse of a right triangle given the measure of an acute angle and the length of a side.

2.5

Using the Sine and Cosine Ratios to Calculate Lengths

Lesson Organizer

60 – 75 min

Key Math Learnings

Because the sine and cosine ratios are constant for a given angle in a right triangle, they can be applied to calculate the length of a side of any right triangle.

Curriculum Focus

Use the sine and cosine ratios to determine lengths indirectly.

SO	AI
M4	4.2, 4.4

Processes

C, CN, PS, R, T, V

Teacher Materials

- demonstration transit

Student Materials

- ruler
- protractor
- scientific calculator

Make Connections, SB page 97

In this lesson, students apply what they learned about the sine and cosine ratios to solving real-world problems.

Students may have seen survey crews at work in forests, on building sites, and on roads. To make a simple transit, use a 360° protractor or a photocopy of one glued to cardboard. Use a needle to pull a thread through the centre of the protractor, then tape the thread at the back of the protractor. Use a paperclip to insert the thread through a straw, then as a weight on the thread. Attach this to a support such as a dowel so that the protractor is horizontal and the weight can hang freely. Illustrate how to sight two objects through the straw, record the angle measure each time, then subtract these measures to determine the angle between the lines of sight.

Ask students how the simple transit resembles the clinometer they made in Lesson 2.3, and how it is different from the clinometer.

Students may suggest that the surveyor measures lengths and an acute angle in such a way that the problem can be represented by a right triangle. Then, one of the three trigonometric ratios can be used depending on which side of the triangle is known and which side is to be determined.

Construct Understanding, SB page 97

Some students may solve the problem with a scale diagram, but their results will not be accurate. Other students may apply the strategies they learned in Lesson 2.4, and set up, then solve, an equation using the cosine ratio. An alternative strategy would be to use the tangent ratio to determine the distance between the survey pole and stake, then use the Pythagorean Theorem.

Assessing Understanding: Observe and Listen

As students work, ask questions such as:

- What difficulties did you have to overcome by using a scale diagram? (*It was not easy to measure an angle of 46.5° accurately with my protractor. I used a scale of 1 cm to represent 10 m, so my answer will not be accurate.*)
- What would you have done if you had to determine the distance between the survey pole and the survey stake? (*I would have used the tangent ratio because I know the adjacent side and I want to find the opposite side.*)

Assessment for Learning

What to look and listen for:

- Students can identify the hypotenuse, the side opposite a given angle, and the side adjacent to a given angle.
- Students can use the sine or cosine ratio to determine the length of the hypotenuse, given the length of a leg and the measure of an acute angle.
- Students can use the sine or cosine ratio to determine the length of a leg given the length of the hypotenuse and the measure of an acute angle.
- Students can use the sine or cosine ratio to solve problems.

DI Identifying Common Difficulties: Possible Intervention

The student has difficulty choosing a strategy.

- Have the student sketch a triangle to represent the problem, and label its vertices. Then ask the student to identify and label the opposite and adjacent sides relative to the given angle, and label the hypotenuse. Ask, “Which side length could you determine by using the tangent ratio?” (*I could find the distance between the survey pole and the survey stake.*) Ask, “When you know the lengths of two sides of a right triangle, how can you determine the length of the third side?” (*I can use the Pythagorean Theorem.*)

DI Extending Thinking

Have students determine the measures of the other acute angle and the other leg of the triangle.

Debrief Think About It: Assessment for Learning

Invite pairs of students to record their solutions on the overhead projector or board. Discuss each strategy. For the strategy that uses the cosine ratio, ask questions such as:

- Why did you choose to use the cosine ratio? (*We knew the length of the side adjacent to a given angle and we had to find the length of the hypotenuse.*)
- How did you write your equation? (*We used the same strategy as for the tangent ratio. We know that $\cos 46.5^\circ$ is equal to the ratio of the adjacent side to the hypotenuse, which is the distance we wanted to find. So, we wrote $\cos 46.5^\circ = \frac{110}{\text{hypotenuse}}$.)*
- How did you solve your equation? (*We multiplied each side by the hypotenuse to get rid of the fraction, then we divided each side by 110 to get $\text{hypotenuse} = \frac{110}{\cos 46.5^\circ}$. We calculated the distance between the transit and the survey pole as about 160 m.*)

Use the diagram of the nested right triangles on Student book page 90 to reinforce that, for a given acute $\angle A$ in a right triangle, the ratio of the opposite side to the hypotenuse is constant, and the ratio of the adjacent side to the hypotenuse is also constant, and that the definitions of the sine and cosine ratio of $\angle A$ make sense.

DI Identifying Common Difficulties: Possible Intervention

The student has difficulty writing the correct equation required to determine the length of a side in a right triangle.

- Have the student sketch the triangle and label the sides relative to the given angle. The student could write the equations for all 3 trigonometric ratios, then identify the ratio that best matches the problem.

DI Extending Thinking

Use the question prompts in the screened boxes of the Student Book.

<p>SB p. 98, Example 1: How could you have used the sine ratio to solve this problem?</p>	<p><i>I could have calculated the measure of $\angle A$ as $90^\circ - 50^\circ = 40^\circ$. Then I would solve the equation:</i></p> $\sin 40^\circ = \frac{BC}{5.2}, \text{ and}$ $BC = 5.2 \sin 40^\circ.$
<p>SB p. 100, Example 3: How could you use the sine ratio instead of the cosine ratio to solve Example 3?</p>	<p><i>I could calculate the measure of $\angle P$ as $90^\circ - 67.3^\circ = 22.7^\circ$. Then I would solve the equation:</i></p> $\sin 22.7^\circ = \frac{20.86}{TP}, \text{ and}$ $TP = \frac{20.86}{\sin 22.7^\circ}.$
<p>How could you use the tangent ratio?</p>	<p><i>I could determine the length of PS first, by solving the equation:</i></p> $\tan 67.3^\circ = \frac{PS}{20.86} \text{ to get}$ <p><i>PS $\hat{=}$ 49.87 m. Then I would use the Pythagorean Theorem to determine the length of TP.</i></p>

Assessing Understanding: Discuss the Ideas, SB page 101*Sample Responses*

1. *It takes less time to calculate than it does to draw, and the calculation provides a more accurate answer.*

2. *I would use the sine ratio:*

- *to calculate the length of the hypotenuse when the leg I know is opposite the angle whose measure I know*
- *to calculate the length of a leg when I know the length of the hypotenuse and the measure of the angle opposite that leg*

I would use the cosine ratio:

- *to calculate the length of the hypotenuse when the leg whose length I know is adjacent to the angle whose measure I know*
- *to calculate the length of a leg when I know the length of the hypotenuse and the measure of the angle adjacent to that leg.*

Exercises, SB page 101

Assessment of Learning – selected questions

AI	4.2	4.4
Question number	5	10

Sample Response; Reflect, SB page 102

I would use the sine or cosine ratio when I have to determine the length of the hypotenuse of a right triangle, and I know the length of one leg and the measure of one acute angle.

I would also use the sine or cosine ratio when I know the length of the hypotenuse and the measure of an acute angle, and I want to determine the length of a leg.

I would use the tangent ratio when I know the length of one leg and I want to determine the length of the other leg.

For example, in $\triangle BCD$, I would use the sine or cosine ratio to determine the length of BD , but I'd use the tangent ratio to determine the length of BC .

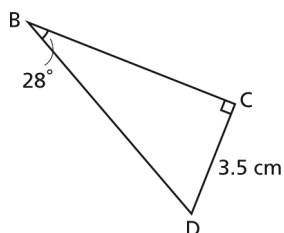

Looking Ahead

In Lesson 2.6, students will use any or all of the trigonometric ratios along with the Pythagorean Theorem to solve triangles; that is, to determine the measures of all unknown angles and sides, and to solve problems.

2.6

Applying the Trigonometric Ratios

Lesson Organizer

60 - 75 min

Key Math Learnings

Any of the trigonometric ratios can be used in a right triangle, along with the Pythagorean Theorem, if sufficient information about the triangle is known.

Curriculum Focus

Use a primary trigonometric ratio to solve a problem modelled by a right triangle.

SO	AI
M4	4.2, 4.3, 4.4

Processes

C, CN, PS, R, T, V

Student Materials

- scientific calculator

Vocabulary

solve a triangle

Make Connections, SB page 105

Discuss vehicles that have wheelchair ramps, and any other places where wheelchair ramps are built. If your school is wheelchair accessible, take the students to a ramp for this discussion.

To be able to use trigonometry to determine the angle of inclination of the ramp, we need to sketch a right triangle to represent the side view of the ramp. In many problem situations, the legs are vertical and horizontal. In this problem, the horizontal leg is the ground so we assume this is level. The hypotenuse represents the length of the ramp. Once we have sketched a right triangle to model the problem, we label it with the given information. We know the length of the leg opposite the angle of inclination and length of the hypotenuse. We must convert one of these measures so the units are the same. To determine the angle of inclination of the ramp, we use the sine ratio:

The sine of the angle = $\frac{4}{39}$; and the angle of inclination is approximately 5.9° .

Construct Understanding, SB page 105

Assessing Understanding: Observe and Listen

As students work, ask questions such as:

- Why did you label your right triangle that way? (*The shorter leg is 1 ft. and it represents the height of the ramp above the ground. The horizontal leg is 20 ft. and it represents the horizontal distance from the point where the ramp touches the ground to the point where the ramp meets the door. The hypotenuse represents the length of the ramp, which I do not know.*)
- How can you use that triangle to determine the angle of inclination of the ramp? (*I shall use the tangent ratio; the tangent of the angle of inclination is the ratio $\frac{1}{20}$, which means the angle of inclination is approximately 2.9° .*)
- Does Anwar's design comply with the building code? (*Yes. 2.9° is less than 5° , so Anwar's design complies.*)

DI Identifying Common Difficulties: Possible Intervention

The student does not understand that the horizontal distance on the ground is equal to the length of one of the legs.

- Provide a triangular prism that the student can use as a visual aid. Ask the student to relate the given distances in the problem to the lengths of edges on the prism. Have the student place the prism on the desk to model the ramp, then draw and label a right triangle to represent the side view of the ramp.

Assessment for Learning

What to look and listen for:

- Students can sketch and label a right triangle to represent a problem.
- Students can identify the trigonometric ratio required to solve a problem.
- Students can use trigonometry and the Pythagorean Theorem to solve a triangle by determining the measures of all unknown sides and angles.

DI Extending Thinking

Ask:

- How could you determine the length of the ramp? (*I would use the Pythagorean Theorem. Let x feet represent the length of the ramp. Then $x = \sqrt{1^2 + 20^2} = 20.0249\dots$. The ramp is approximately 20 ft.*)

Debrief Think About It: Assessment for Learning

Invite some students to record their solutions on the board. Ask questions such as:

- Why did you use the tangent ratio? (*In the right triangle, the only side lengths I knew were those of the side opposite the angle and the side adjacent to the angle. The tangent ratio is $\frac{\text{opposite}}{\text{adjacent}}$.*)

As you work through Example 1, ask:

- Which method do you think you would like to use? (*I prefer Method 1 because I determine the length of the third side first, and once I know all the sides, I can use any trigonometric ratio I like. I prefer Method 2 because there is less work in using trigonometric ratios twice instead of using the Pythagorean Theorem.*)

DI Identifying Common Difficulties: Possible Intervention

The student has difficulty knowing where to start when solving a triangle. Have the student:

- Sketch the right triangle and label it with the given information.
- Circle the angle to be determined or for which the measure is provided, then name and label the hypotenuse and the opposite and adjacent sides.
- Identify which measures and lengths in the triangle are known and which are not known. Use these data to select the correct trigonometric ratio.

DI Extending Thinking

Use the question prompts in the screened boxes of the Student Book.

SB p. 107, Example 1: Which other trigonometric ratio could you have used in Method 1? Why might it be better to use this ratio?	<i>I could have used the tangent ratio to determine the measure of either $\angle X$ or $\angle Z$. If I use this ratio, I am using given data. If I use the cosine ratio, I use calculated data, and if I had made a mistake using the Pythagorean Theorem, then my angle calculation would also be wrong. It might be better to use given data when I can.</i>
SB p. 108, Example 2: What is the advantage of determining the unknown angle before the unknown sides?	<i>I can then write an equation for $\tan D$ in which the unknown length is in the numerator of the fraction. This is an easier equation to solve than one in which the unknown length is in the denominator.</i>

Assessing Understanding: Discuss the Ideas, SB page 110

Sample Responses

- If I know the length of one side and the measure of one acute angle, I would calculate the measure of the other acute angle first. Then I could use any trigonometric ratio I like to calculate the side lengths. Even if I was given the lengths of two sides, I would still probably calculate the measure of an angle first. I prefer to use trigonometry rather than the Pythagorean Theorem, because I find that trigonometry is quicker.*
- If I know only the measures of the angles in a right triangle, I could draw many different sized similar triangles. I cannot solve a right triangle unless I know the measures of one side and one acute angle, or the measures of two sides.*

Exercises, SB page 111

Remind students to sketch and label a diagram to represent a problem. Even if the diagram is given in the Student book, students should redraw it and label it with the measures as they calculate them.

Assessment of Learning – selected questions

AI	4.2	4.3	4.4
Question number	5	7	10

Sample Response: Reflect, SB page 112

To be able to solve a right triangle, I need to know the measures of one angle and one side, or the measures of two sides. For example:

In $\triangle CDE$, I know 2 sides, so I'd use the Pythagorean Theorem first to find the third side, then I'd use any trigonometric ratios I like to find the acute angles. I use trigonometry to calculate both angles to check that they add to 90° and then I know I have not made a mistake.

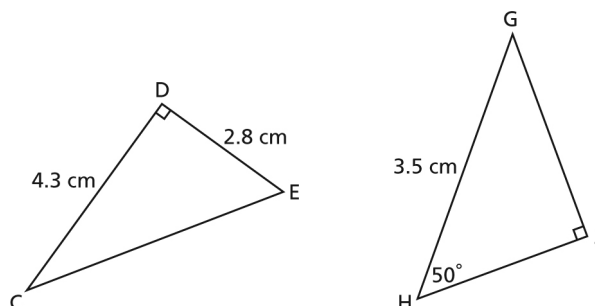

In $\triangle GHJ$, I know one side and one angle, so I first subtract 50° from 90° to find the other acute angle, then I use trigonometry to calculate the lengths of the other sides. I use the Pythagorean Theorem to check that I have calculated the sides correctly.

Looking Ahead

In Lesson 2.7, students will solve problems involving two right triangles and sometimes these triangles will be in different planes. Students may find it easier to visualize a problem if you provide large cardboard or plastic right triangles that they can work with.

Solving Problems Involving More than One Right Triangle

Lesson Organizer

60 – 75 min

Key Math Learnings

Many problems involve one or more right triangles that may be in different planes.

Curriculum Focus

Use trigonometry to solve problems modelled by more than one right triangle.

SO	AI
M4	4.2, 4.4

Processes

C, CN, PS, R, T, V

Teacher Materials

- large model of a square pyramid
- large cardboard or plastic right triangles

Student Materials

- ruler
- protractor
- Master 2.6 (optional)

Vocabulary

angle of depression

Make Connections, SB page 113

This lesson presents students with problems that require multi-step solutions: students have to calculate a measure in one right triangle that they will then use to determine another measure in a second triangle.

Use a model of a square pyramid to represent the Muttart Conservatory pyramid. Have student volunteers identify, then indicate on the model, the apex, faces, slant edges, height, and the angle between two slant edges.

As a class, have students discuss and suggest how to determine the angle between the slant edges before they work in pairs to solve the problem.

At the end of the lesson, you may wish to revisit and solve this problem.

Construct Understanding, SB page 113

Assessing Understanding: Observe and Listen

Students will likely begin by sketching the triangular faces and then realize they do not have enough information to use a trigonometric ratio to determine the measure of the angle between the slant edges. As you ask questions, have the student point to his sketch or the model pyramid to aid comprehension. Ask questions, such as:

- The height of the pyramid is measured from the centre of the base. How far is this point from one side of the base? (*The distance between the centre of the base and one side of the base is one-half the side length of the base, which is 13 m.*)
- How could you draw a right triangle that has the height of the pyramid and its distance from one side of the base as its legs? (*I could draw a line of symmetry of that face and it would be the hypotenuse of the right triangle.*)
- When you know the length of the hypotenuse of that triangle, how could you calculate the angle between the slant edges? (*I would use the right triangle that is one-half the triangular face. The height of the face is one leg and one-half the base is the other leg, so I would use the tangent ratio to calculate one-half the angle, then double my answer.*)

DI Identifying Common Difficulties: Possible Intervention

Students may have difficulty sketching a square pyramid.

- Provide students with copies of Master 2.6 on which they can sketch their right triangles.

Students may have difficulty knowing where to begin solving the problem. Ask:

- What type of triangle is each face of the pyramid? (*It's an isosceles triangle because the two slant edges of the pyramid are equal.*)

- Draw the line of symmetry of the triangle. What do you know about the two triangles that are formed? (*The triangles match and each triangle is a right triangle because the line of symmetry is perpendicular to the base of the isosceles triangle.*)

Students may have difficulty visualizing the right triangles inside the pyramid.

- Use a transparency of Master 2.6 on the overhead projector, along with the model pyramid, to illustrate $\triangle ABC$, described in the solution below.

DI Extending Thinking

Have students calculate the measure of the angle between a slant edge and a diagonal of the base of the pyramid. Ask:

- What do you need to know to be able to determine the measure of that angle? (*I know the length of one leg of the triangle, which is the height of the pyramid; so I need to find the length of another leg or the hypotenuse.*)
- Which measure would be easier to calculate? (*I could use the Pythagorean Theorem to calculate the length of a diagonal of the base because I know the lengths of the sides of the base. This length is about 36.77 m. Then I halve the diagonal to get the measure of the other leg in my triangle, which is about 18.38 m.*)
- How will you calculate the measure of the angle? (*Because I know the measures of the legs, I'll use the tangent ratio. The angle is approximately 52.5° .*)

Debrief Think About It: Assessment for Learning

- Invite a pair of students to record their solution to the problem on the overhead projector or board. If students use the overhead projector, provide a transparency of Master 2.6 so they can illustrate the right triangles they used. Here is one possible solution:

In $\triangle ABC$:

Use the Pythagorean Theorem to calculate AC.

$$\begin{aligned} AC &= \sqrt{24^2 + 13^2} \\ &= 27.2946\dots \end{aligned}$$

In $\triangle ACE$:

$$\begin{aligned} \tan A &= \frac{13}{27.2946\dots} \\ \angle A &= 25.4676\dots^\circ \end{aligned}$$

In $\triangle ADE$:

$$\begin{aligned} \angle DAE &= 2(25.4676\dots^\circ) \\ &\doteq 51^\circ \end{aligned}$$

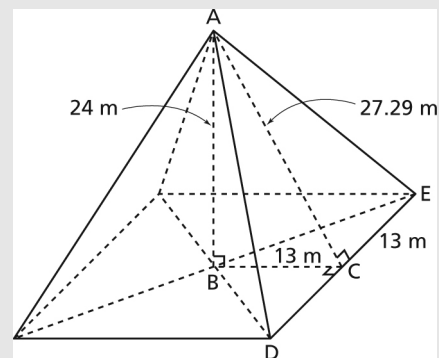

Example 2 introduces the angle of depression. Have students suggest situations in the classroom that could illustrate this concept, such as the angle of depression of an eraser on the floor. Student could use their clinometers to measure this angle.

DI Identifying Common Difficulties: Possible Intervention

When presented with a problem that involves two right triangles, the student does not know which triangle to start with.

- Have the student outline one triangle and circle the given measures in that triangle. On a second copy of the diagram, have the student outline the other triangle and circle its given measures. The student then looks at each triangle in turn, to decide which triangle has enough information to be able to use any trigonometric ratio or the Pythagorean Theorem.

Student cannot visualize the right triangles in two planes.

- Provide the students with cardboard or plastic right triangles and have them work in pairs. One student holds the triangles to represent the problem, while the other student identifies the relevant sides and angles, then sketches a diagram.

DI Extending Thinking

Use the question prompts in the screened boxes of the Student Book.

<p>SB p. 114, Example 1: Explain how you could calculate all the unknown sides and angles of quadrilateral ABCD.</p>	<p><i>In $\triangle ABD$, I would use the Pythagorean Theorem to calculate the length of AB; then subtract 47° from 90° to calculate $\angle BDA$. In $\triangle BCD$, I would use the sine ratio to calculate the length of BC; then subtract 26° from 90° to calculate $\angle CBD$. I would then add the measures of adjacent angles to get the measures of $\angle ABC$ and $\angle ADC$.</i></p>
<p>SB p. 116, Example 2: Suppose you did not evaluate a decimal equivalent for QS. What expression would you need to use to determine the length of PS?</p>	$QS = \frac{20}{\tan 15^\circ}; PS = QS \tan 30^\circ$ $\text{So, } PS = \frac{20}{\tan 15^\circ} (\tan 30^\circ)$
<p>SB p. 117, Example 3: Solve Example 3 using your calculator only once. Explain why this might be more efficient and accurate than calculating intermediate lengths.</p>	$WT = 90 \tan 85^\circ; TS = 90 \tan 88^\circ$ $\text{So, } SW = \sqrt{(90 \tan 85^\circ)^2 + (90 \tan 88^\circ)^2}$ $= 2774.9805\dots$ <p><i>Each time I calculate an intermediate measure, it adds a step to the calculation and I lose some accuracy. Calculating in a single step also saves time.</i></p>

Assessing Understanding: Discuss the Ideas, SB page 118

Sample Responses

1. I have to remember that, to make a diagram look three-dimensional, I may have to draw an angle that does not measure 90° but which represents a right angle. It usually helps to draw a vertical line segment vertically on the page. It is important to label all right angles as soon as possible.
2. I first identify the line segment or angle I am to determine. Then, I focus on the triangle(s) to which it belongs. I choose one triangle to attempt to determine the measure. If I do not have sufficient information about that triangle to determine the measure, I use the other triangle to determine the missing information.

Exercises, SB page 118

Remind students that a diagram showing all the given information is an essential step in the problem-solving process.

Assessment of Learning – selected questions

AI	4.2	4.4
Question number	5	8

Sample Response; Reflect, SB page 121

This is how I solved the problem in question 8:

I started by drawing a diagram that shows all the information about the situation.

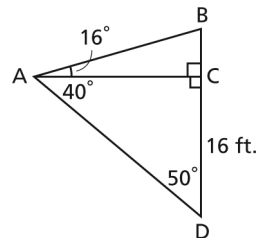

In $\triangle ACD$, to calculate AC , I first used the fact that $\angle ACD = 90^\circ$ and calculated $\angle ADC = 90^\circ - 40^\circ$

$$\angle ADC = 50^\circ.$$

I then used the tangent ratio because I wanted to find the opposite side and I

knew the adjacent side: $\tan 50^\circ = \frac{AC}{16}$; so $AC = 16 \tan 50^\circ$

$$AC = 19.068... \text{ ft.}$$

The height of the tree is $BD = BC + CD$.

In $\triangle ABC$, $AC = 19.068... \text{ ft.}$, so $\tan 16^\circ = \frac{BC}{19.068...}$,

$$BC = 5.467...$$

$CD = 16 \text{ ft.}$, so $BD = 5.467... \text{ ft.} + 16 \text{ ft.}$

$$BD \doteq 21 \text{ ft.}$$

Master 2.1a Activate Prior Learning: Similar Triangles

For similar triangles $\triangle ABC$ and $\triangle A'B'C'$:

- The **corresponding angles** are:
 $\angle A = \angle A'$; $\angle B = \angle B'$; $\angle C = \angle C'$
- The **corresponding sides** are:
 AB and $A'B'$; BC and $B'C'$; AC and $A'C'$

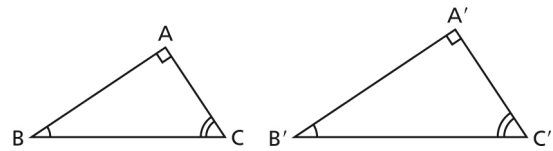

In two right triangles, the right angles are a pair of equal corresponding angles.
 For two right triangles to be similar, we need only know that:

- the measures of two corresponding acute angles are equal:
 either $\angle P = \angle P'$ or $\angle R = \angle R'$

or

- the ratios of two pairs of corresponding sides are equal:

$$\text{either } \frac{PQ}{P'Q'} = \frac{PR}{P'R'} \text{ or } \frac{PQ}{P'Q'} = \frac{QR}{Q'R'} \text{ or } \frac{QR}{Q'R'} = \frac{PR}{P'R'}$$

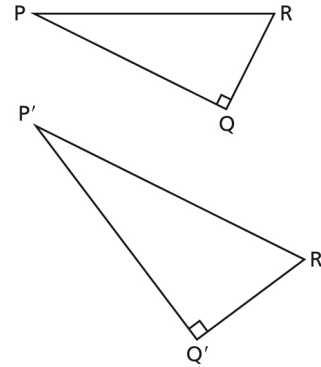

Check Your Understanding

1. Which triangles below are similar to $\triangle XYZ$?
 Explain how you know.

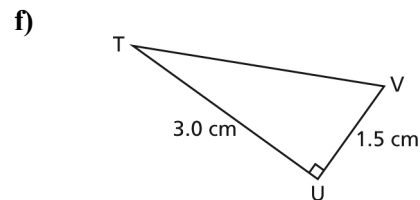
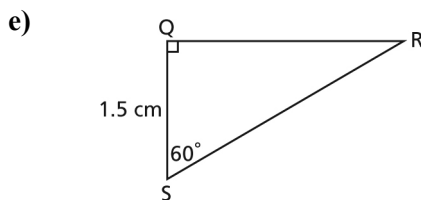
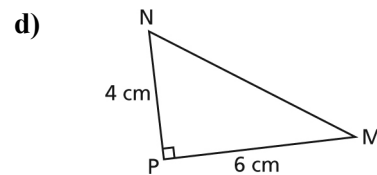
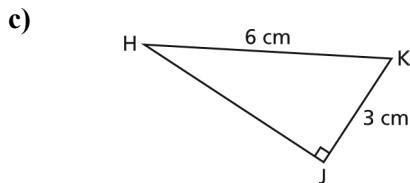
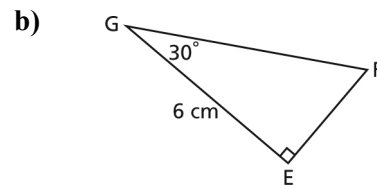
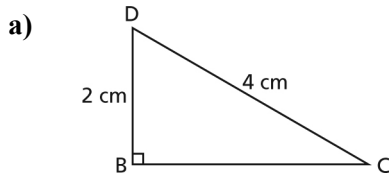
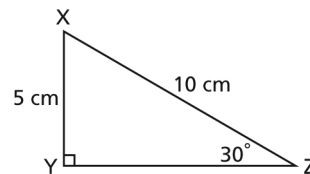

Master 2.1b Activate Prior Learning: Solving Equations of the Form: $b = \frac{x}{a}$ and $b = \frac{a}{x}$, $x \neq 0$

To solve an equation, we determine the value of the variable.

To do this, we isolate the variable on one side of the equation.

When an equation contains a fraction, we multiply both sides of the equation by the denominator of the fraction and simplify.

- To solve an equation of the form $b = \frac{x}{a}$

Solve: $10 = \frac{x}{3}$ Since 3 is the denominator of the fraction, multiply both sides by 3.

$$3(10) = 3\left(\frac{x}{3}\right) \quad \text{Simplify both sides of the equation.}$$

$$30 = x$$

The solution is $x = 30$.

- To solve an equation of the form $b = \frac{a}{x}$, $x \neq 0$

Solve: $5 = \frac{4}{n}$ Since n is the denominator of the fraction, multiply both sides by n .

$$n(5) = n\left(\frac{4}{n}\right) \quad \text{Simplify.}$$

$$5n = 4$$

To solve the equation, isolate the variable by dividing both sides by 5.

$$\frac{5n}{5} = \frac{4}{5}$$

Simplify.

$$n = \frac{4}{5}, \text{ or } 0.8$$

The solution is $n = \frac{4}{5}$, or 0.8.

Check Your Understanding

1. Solve each equation.

a) $12 = \frac{m}{3}$

b) $10 = \frac{t}{2}$

c) $\frac{s}{1.2} = 5$

d) $\frac{v}{9} = 1.1$

2. Solve each equation.

a) $10 = \frac{3}{v}$

b) $24 = \frac{8}{u}$

c) $\frac{3.6}{r} = 6$

d) $\frac{12}{t} = 0.4$

Master 2.1c Activate Prior Learning: The Pythagorean Theorem

In a right triangle, the Pythagorean Theorem states that the square of the hypotenuse is equal to the sum of the squares of the legs. The area model as shown is one way to prove this is true.

$$\text{We write: } c^2 = a^2 + b^2$$

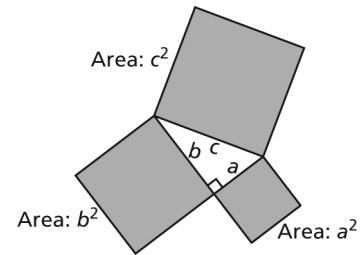

- To determine the length of the hypotenuse when we know the lengths of the legs
In $\triangle BCD$, determine the length of BD to the nearest tenth of a centimetre.

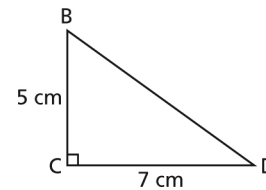

Use the Pythagorean Theorem.

$$BD^2 = BC^2 + CD^2 \quad \text{Substitute: } BC = 5 \text{ and } CD = 7$$

$$BD^2 = 5^2 + 7^2$$

$$BD = \sqrt{5^2 + 7^2} \quad \text{Use a calculator.}$$

$$= 8.6023\dots$$

BD is about 8.6 cm long.

- To determine the length of a leg when we know the lengths of the other leg and the hypotenuse
In $\triangle EFG$, determine the length of EF to the nearest tenth of a centimetre.

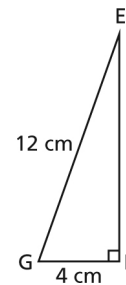

Use the Pythagorean Theorem.

$$EG^2 = EF^2 + FG^2 \quad \text{Substitute: } EG = 12 \text{ and } FG = 4$$

$$12^2 = EF^2 + 4^2 \quad \text{Solve for } EF.$$

$$EF^2 = 12^2 - 4^2$$

$$EF = \sqrt{12^2 - 4^2}$$

$$= 11.3137\dots$$

EF is about 11.3 cm long.

Check Your Understanding

- Determine the length of each side AB to the nearest tenth of a centimetre.

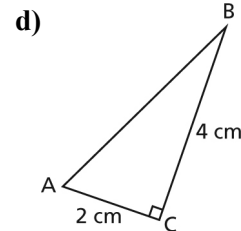
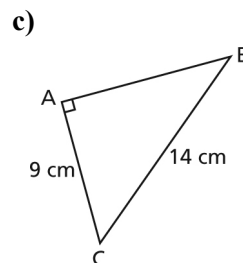
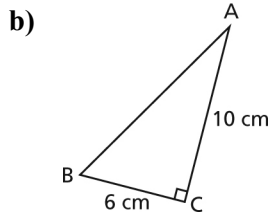
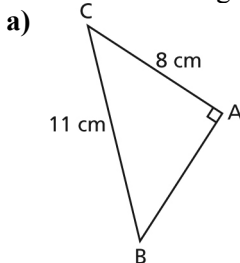

Name: _____

Date: _____

Master 2.2 The Tangent Ratio

Measure of $\angle A$	Value of $\frac{CB}{BA}$		
	Original Triangle	Similar Triangle 1	Similar Triangle 2

Name: _____

Date: _____

Master 2.3 Large Protractor

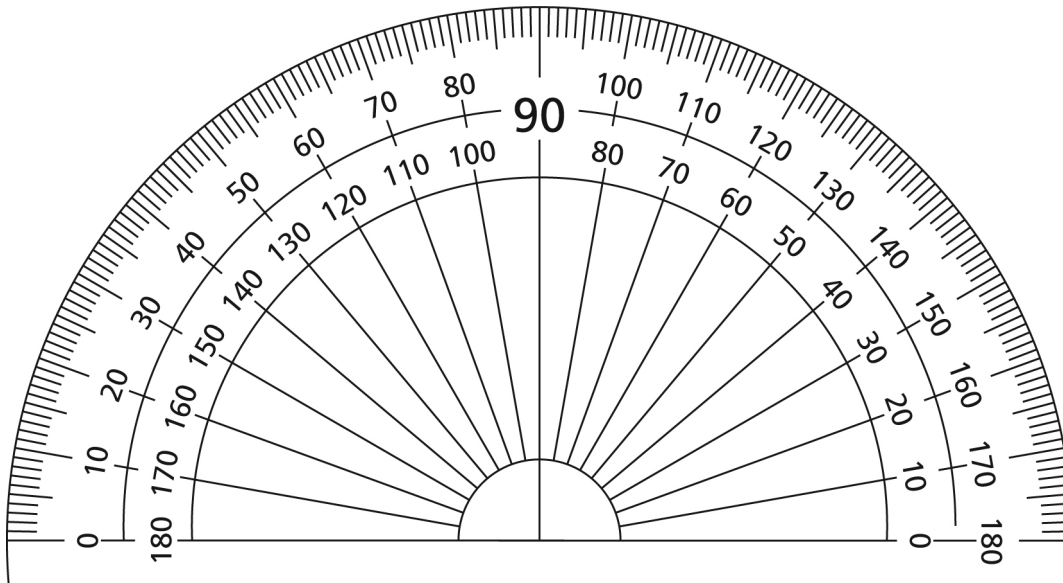

Master 2.3

The right to reproduce or modify this page is restricted to purchasing schools.
This page may have been modified from its original. Copyright © 2010 Pearson Canada Inc.

Name: _____

Date: _____

Master 2.4 Math Lab Recording Sheet

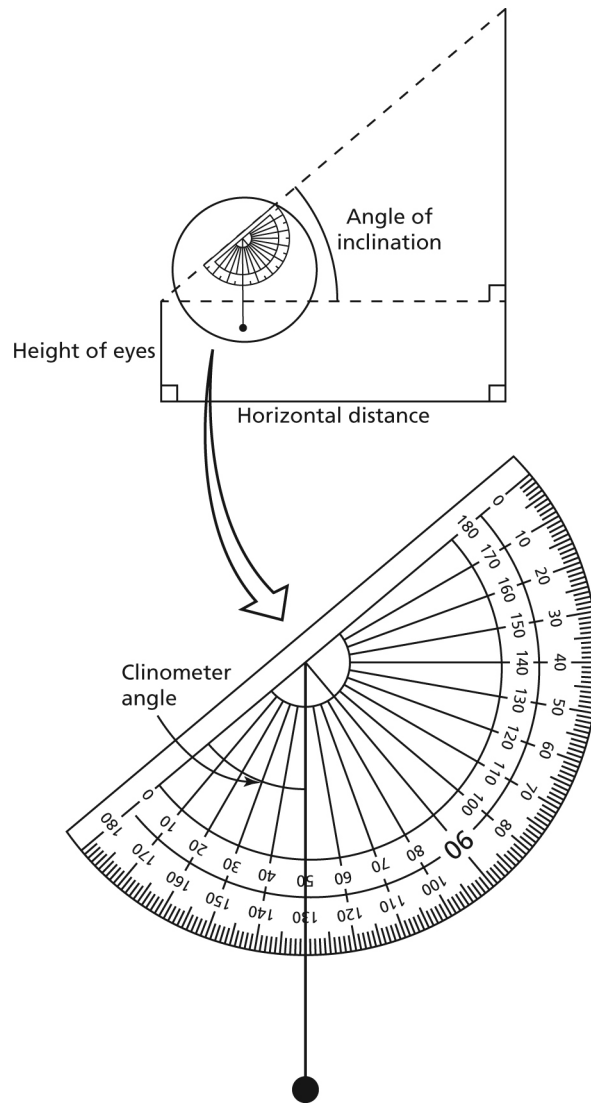

Horizontal distance: _____

Height of eyes: _____

Clinometer angle: _____

Angle of inclination: _____

Name: _____

Date: _____

Master 2.5 Recording Sheet for Lesson 2.4 Try This

Triangle	Measures of Sides			Ratios	
	Hypotenuse	Side opposite $\angle A$	Side adjacent to $\angle A$	$\frac{\text{Side opposite } \angle A}{\text{Hypotenuse}}$	$\frac{\text{Side adjacent to } \angle A}{\text{Hypotenuse}}$
$\triangle ABC$					
$\triangle ADE$					
$\triangle AFG$					
$\triangle AHJ$					

For your triangles:

Triangle	Measures of Sides			Ratios	
	Hypotenuse	Side opposite $\angle A$	Side adjacent to $\angle A$	$\frac{\text{Side opposite } \angle A}{\text{Hypotenuse}}$	$\frac{\text{Side adjacent to } \angle A}{\text{Hypotenuse}}$

Name: _____

Date: _____

Master 2.6 Square Pyramid for Lesson 2.7 Think About It

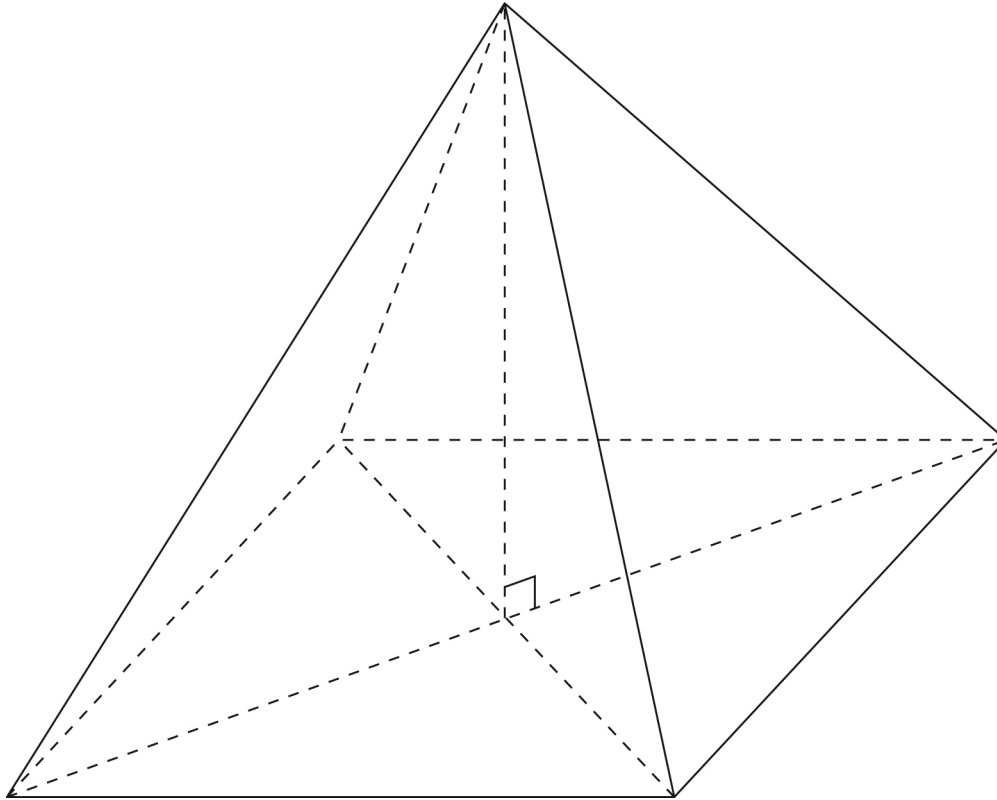

Master 2.7 Chapter Test

For questions 1 and 2, choose the correct answer: A, B, C, or D

1. For $\triangle DEF$, how many of these statements are true?

$$\cos \angle D = \frac{12}{13}$$

$$\sin \angle D = \frac{5}{13}$$

$$\tan \angle D = \frac{5}{12}$$

$$\tan \angle F = 2.4$$

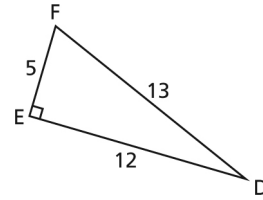

- A. 1 is true. B. 2 are true. C. 3 are true. D. All are true.

2. In right $\triangle DEF$, with $\angle E = 90^\circ$, which statement is false?

As $\angle D$ decreases:

A. $\sin \angle D$ increases.

B. $\sin \angle F$ increases.

C. $\cos \angle D$ increases.

D. $\cos \angle F$ decreases.

3. a) Solve each triangle. Give your answers to the nearest tenth.

i)

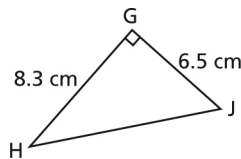

- ii) Right $\triangle KMN$ with $\angle M = 90^\circ$, $\angle N = 26^\circ$, and $KN = 15.0$ cm.

- b) When you solved the triangles in part a, did you use the same strategies?

If your answer is yes, describe your strategy.

If your answer is no, explain why you used different strategies.

4. The angle of inclination of a conveyor is 8° . The conveyor rises 0.75 m.
What is the length of the conveyor? Give your answer to the nearest hundredth of a metre.
5. A helicopter is hovering at a height of 300 m.
From the helicopter, the angle of depression of the top of a wind turbine is 40°
and the angle of depression of the base of the turbine is 48° .
Determine the height of the turbine, to the nearest tenth of a metre.

Master 2.8 Answers

Master 2.1a

1. a) Since $\frac{XY}{DB} = \frac{XZ}{DC} = \frac{5}{2}$; then $\triangle XYZ \sim \triangle DBC$
- b) Since $\angle Z = \angle G = 30^\circ$; then $\triangle XYZ \sim \triangle FEG$
- c) Since $\frac{JK}{YX} = \frac{KH}{XZ} = \frac{3}{5}$, then $\triangle JKH \sim \triangle YXZ$
- d) The ratios of two pairs of corresponding sides are not equal, so the triangles are not similar.
- e) $\angle R = 30^\circ = \angle Z$, so $\triangle XYZ \sim \triangle SQR$
- f) The ratios of two pairs of corresponding sides are not equal, so the triangles are not similar.

Master 2.1b

- | | | | |
|-----------------|--------------|--------------|--------------|
| 1 a) $m = 36$ | b) $t = 20$ | c) $s = 6$ | d) $v = 9.9$ |
| 2. a) $v = 0.3$ | b) $u = 0.3$ | c) $r = 0.6$ | d) $t = 30$ |

Master 2.1c

1. a) $AB \doteq 7.5$ cm b) $AB \doteq 11.7$ cm c) $AB \doteq 10.7$ cm d) $AB \doteq 4.5$ cm

Master 2.7 Chapter Test

1. D
2. A
3. a) i) $JH \doteq 10.5$ cm; $\angle H \doteq 38.1^\circ$; $\angle J \doteq 51.9^\circ$
 ii) $MN \doteq 13.5$ cm; $KM \doteq 6.6$ cm; $\angle K = 64^\circ$
- b) Answers may vary. No, I used different strategies. In $\triangle GHJ$, I used the Pythagorean Theorem first to calculate the length of the third side, then I used the tangent ratio to calculate the angle measures. In $\triangle KMN$, I used the sine and cosine ratios to calculate the lengths of the legs, then I subtracted the given angle from 90° to calculate the other acute angle. I didn't need the Pythagorean Theorem.
4. The conveyor is about 5.39 m long.
5. $TB = 73.3$ m

Master 2.9 Chapter Project: Indirect Measurement

Work with a partner.

You will need:

- an empty carton that has the shape of a rectangular prism
- a metre stick

Part 1

- Measure the dimensions of the carton.
- Place the metre stick in the carton along a diagonal of one face, labelled A, as shown.
Use your measurements to calculate the angle of inclination of the stick.
- Place the carton on the floor near a wall, with the stick just touching the wall. Face A should be perpendicular to the wall.
Calculate how far up the wall the stick reaches. Describe your strategy.
Check your answer by measuring.
Explain why the calculated height may be different from the measured height.

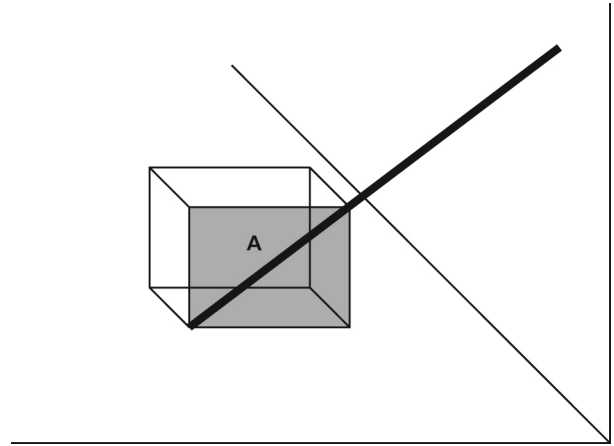

Part 2

- Place the metre stick in the carton along the body diagonal, as shown.
Calculate the angle of inclination of the stick.
- Place the carton on the floor near a wall, with the stick just touching the wall. Face A should be perpendicular to the wall.
Calculate how far up the wall the stick reaches. Describe your strategy.
Check your answer by measuring.
Explain why the calculated height may be different from the measured height.

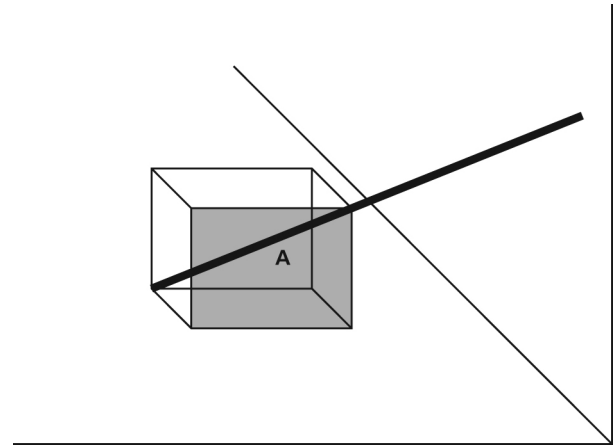

Part 3

- Why are the angles of inclination in Parts 1 and 2 different?
- Why are the heights in Parts 1 and 2 different?

Master 2.10 Chapter Rubric: Trigonometry

	Not Yet Adequate	Adequate	Proficient	Excellent
Conceptual Understanding				
<ul style="list-style-type: none"> Shows understanding by demonstrating and explaining: <ul style="list-style-type: none"> - why two right triangles are similar - why the same trigonometric ratios for corresponding acute angles in similar right triangles are equal. 	little understanding; may be unable to demonstrate or explain: <ul style="list-style-type: none"> - why two right triangles are similar - why the same trigonometric ratios for corresponding acute angles in similar right triangles are equal 	shows understanding; partially able to demonstrate and explain: <ul style="list-style-type: none"> - why two right triangles are similar - why the same trigonometric ratios for corresponding acute angles in similar right triangles are equal 	shows understanding; able to appropriately demonstrate and explain: <ul style="list-style-type: none"> - why two right triangles are similar - why the same trigonometric ratios for corresponding angles in similar right triangles are equal 	shows depth of understanding; in a general context, able to thoroughly demonstrate and explain: <ul style="list-style-type: none"> - why two right triangles are similar - why the same trigonometric ratios for corresponding angles in similar right triangles are equal
Procedural Knowledge				
<ul style="list-style-type: none"> Identifies the hypotenuse of a right triangle, and the opposite and adjacent sides for a given acute angle. Applies the primary trigonometric ratios to: <ul style="list-style-type: none"> - determine the measure of an acute angle in a right triangle - determine the length of a side in a right triangle 	has difficulty independently: <ul style="list-style-type: none"> - identifying the hypotenuse of a right triangle, and the opposite and adjacent sides for a given acute angle - determining the measure of an acute angle and the length of a side in a right triangle 	is generally able to: <ul style="list-style-type: none"> - identify the hypotenuse of a right triangle, and the opposite and adjacent sides for a given acute angle - determine the measure of an acute angle and the length of a side in a right triangle 	generally accurate; few errors or omissions in: <ul style="list-style-type: none"> - identifying the hypotenuse of a right triangle, and the opposite and adjacent sides for a given acute angle - determining the measure of an acute angle and the length of a side in a right triangle 	accurate; no errors or omissions in: <ul style="list-style-type: none"> - identifying the hypotenuse of a right triangle, and the opposite and adjacent sides for a given acute angle - determining the measure of an acute angle and the length of a side in a right triangle
Problem-Solving Skills				
<ul style="list-style-type: none"> Solves right triangles. Solves a problem that involves one or more right triangles by applying the primary trigonometric ratios or the Pythagorean Theorem. 	does not use appropriate strategies to: <ul style="list-style-type: none"> - solve a right triangle - solve a problem that involves one or more right triangles by applying the primary trigonometric ratios or the Pythagorean Theorem 	uses some appropriate strategies to: <ul style="list-style-type: none"> - solve a right triangle - solve a problem that involves one or more right triangles by applying the primary trigonometric ratios or the Pythagorean Theorem 	uses appropriate strategies to: <ul style="list-style-type: none"> - solve a right triangle - solve a problem that involves one or more right triangles by applying the primary trigonometric ratios or the Pythagorean Theorem 	uses effective and innovative strategies to: <ul style="list-style-type: none"> - solve a right triangle - solve a problem that involves one or more right triangles by applying the primary trigonometric ratios or the Pythagorean Theorem
Communication				
<ul style="list-style-type: none"> Records and explains reasoning and procedures clearly and completely, including fully-labelled diagrams and uses appropriate terminology. 	<ul style="list-style-type: none"> - unable to record and explain reasoning and procedures clearly and completely - diagrams are incomplete or incorrect and omit key information 	<ul style="list-style-type: none"> - records and explains reasoning and procedures with partial clarity; may be incomplete - diagrams are partially complete and may contain errors or omissions 	<ul style="list-style-type: none"> - records and explains reasoning and procedures clearly and completely - diagrams have few errors or omissions 	<ul style="list-style-type: none"> - records and explains reasoning and procedures with precision and thoroughness - diagrams are complete and have no errors

Master 2.11a Chapter Summary: Self-Assessment and Review

1. Read the **Description** column below.

Decide which description matches how you feel about each Review question.

Write the question number in the **Before** column based on your comfort level.

Before			After
Review Question	Symbol	Description	Review Question
	✓	<ul style="list-style-type: none"> • I can do this type of question very well. • I understand this idea. • I can explain to someone else how to do this question. • If there are lots of questions like this on the test, I will do well. 	
	?	<ul style="list-style-type: none"> • I can sometimes do this type of question. • I understand some of this idea. • If someone gets me started on this question, I can usually get it right. • If there are lots of questions like this on the test, I will do alright but not well. 	
	✗	<ul style="list-style-type: none"> • I don't know how to do this type of question. • I don't understand this idea. • I need help starting and finishing this type of question. • If there are lots of questions like this on the test, I won't do well. 	

Spend your time reviewing the questions you identified in the bottom two rows of the table.

- Make a study plan. The table on Master 2.11b shows you where in the chapter you can find help for each Review question. You can:
 - Work through the pages where you can find help on your own. Then ask for help if you still don't get it.
 - Work with a friend who can help you.
 - Ask your teacher for help.
- When you have finished working through the pages that should help you, complete the Review questions. Write each Review question number in the **After** column based on your comfort level now. Ask your teacher for help with any questions that are still in the bottom two rows.

Name: _____

Date: _____

Master 2.11b Chapter Summary: Review Question Correlation

Where to Find Help			
Review Question	Example:	Solutions to Exercises question:	Checkpoint:
#1	#2, page 72	#5, page 75; #1 a), b), page 88	#1, page 87
#2		#7, page 75	
#3	#3, page 73	#10, #11, page 76	
#4		#16, page 76	
#5	#1, #2, page 79	#3, #4, #5, page 82; #9, page 83; #4, page 88	#1, page 87
#6	#3, page 81	#6, #7, #8, page 82; #5, page 88	
#7		#11, page 83	
#8	#3, page 81	#6, #7, #8, page 82; #5, page 88	
#9		#10, #13, page 83	
#10		#2, #3, page 86	
#11	#2, page 93	#7, #8, #10, page 95; #1, page 104	#2, page 103
#12		#9, page 95; #16, page 96	
#13	#3, page 94	#11, #13, page 96	
#14		#14, page 96	
#15	#1, page 98; #2, page 99	#3, #4, #5, page 101; #4, page 104	#2, page 103
#16		#9, page 102	
#17		#10, page 102	
#18	#1, page 106; #2, page 108	#6, page 111	
#19		#12, page 96	
#20		#12, page 112	
#21	#2, page 108	#4d), page 111	
#22		#5c), page 118	
#23		#6, page 118; 9, page 119	

Lesson Organizer

180 - 225 min

Curriculum FocusMeasurement Strand
Performance Assessment**Student Materials**

- scientific calculator
- ruler, metre stick, or measuring tape
- protractor
- computer with Internet access

This project can be assigned after Chapters 1 and 2 have been completed. It gives students the opportunity to apply to a real-world problem what they learned about converting between SI and imperial units, trigonometric ratios, and surface area.

To initiate a discussion about wheelchair accessibility, ask if any students have a family member or friend who uses a wheelchair. Point out that when a wheelchair ramp is constructed correctly, it offers people who use wheelchairs the ability to easily access the building. Discuss why most building codes require wheelchair ramps to meet certain specifications; for example, a steep ramp is difficult to climb; edge protection and handrails provide safety; resting places on long ramps allow users to take a break; and landing areas at the top and bottom of the ramp allow users to open a door or to stop before making a turn.

Present the *Project*. Encourage students to visit and take measurements of existing ramps in the community before they start their own designs. Remind students that the number of decimal places in a computed calculation should be the same as the number of decimal places in the least precise measurement used in the calculation.

Provide students with sufficient time to research material costs. This could be done using the Internet or by visiting a local building supplier. You might consider having a representative from a local building supplier come to class to meet with students. Remind students that building supplies, such as lumber and plywood, are sold in imperial measures. So, students will have to convert between SI and imperial measures to estimate costs. Tell students to assume that 2 coats of non-slip paint will be required to coat the ramp. Remind students that paint can only be purchased in whole numbers of cans and this should be considered when estimating the cost of coating the ramp.

Not all students should be required to complete the Extension. Encourage strong math students or early finishers to draw a scale diagram of the ramp, either by hand or by using computer graphics software.

DI Identifying Common Difficulties: Possible Intervention

The student does not know how to estimate the cost of covering the ramp with non-slip paint.

- The label on a can of paint indicates the area the paint covers in square feet. The student should determine the area of the surface of the ramp in square feet, divide by the coverage area, then double the answer to determine the number of cans required. This number is then multiplied by the cost of a can of paint.

Name: _____ Date: _____

Project Observation Checklist: Ramp It Up!

Name	Conceptual Understanding	Procedural Knowledge	Problem-Solving Skills	Communication
	<ul style="list-style-type: none"> • Students can choose the appropriate trigonometric ratio to determine the measure of an unknown side or angle in a right triangle 	<ul style="list-style-type: none"> • Students accurately: <ul style="list-style-type: none"> – convert measurements between systems – calculate the surface area of the ramp – estimate the cost to construct and coat the ramp 	<ul style="list-style-type: none"> • Students can design a ramp that meets given requirements 	<ul style="list-style-type: none"> • Students draw a labelled diagram of the ramp that shows all lengths and angle measures • Students provide explanations to support the design of the ramp

PEARSON

Foundations and Pre-calculus Mathematics 10

Robert Berglind
Garry Davis
Edward Doolittle
David Ellis
Jack Hope
Delcy Rolheiser
David Sufrin
Chris Van Bergeyk
David Van Bergeyk
David Zimmer

Copyright © 2010 Pearson Canada Inc.
All rights reserved.

This publication is protected by copyright, and permission should be obtained from the publisher prior to any prohibited reproduction, storage in a retrieval system, or transmission in any form or by any means, electronic, mechanical, photocopying, recording, or likewise. For information regarding permission, write to the Permissions Department.

Pages identified as line masters may be copied by the purchasing school for classroom use.

Printed and bound in Canada

1 2 3 4 5 – WC – 14 13 12 11 10

PEARSON