

Please feel free to modify this text to make the letter your own.

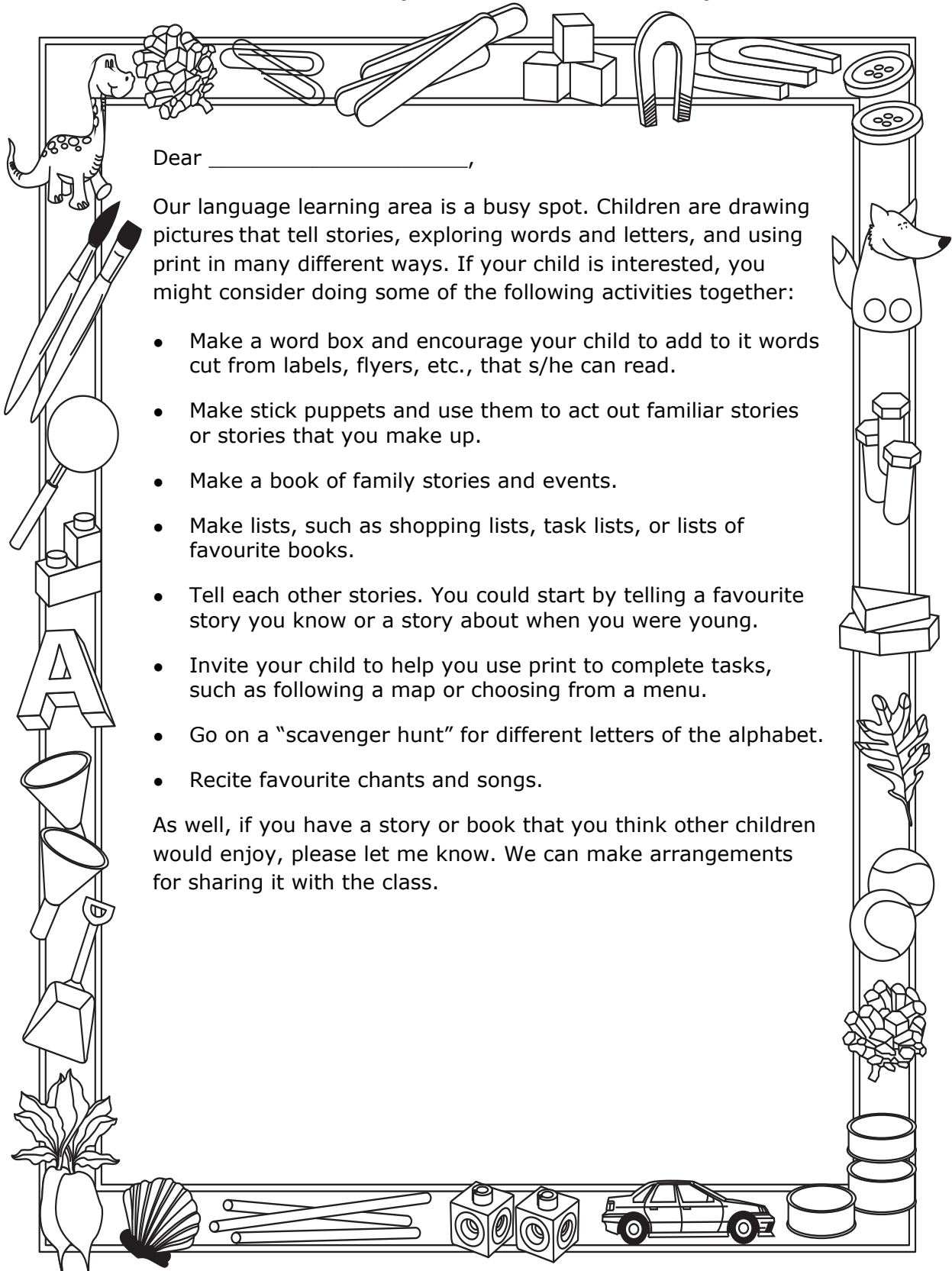

Dear _____,

Our language learning area is a busy spot. Children are drawing pictures that tell stories, exploring words and letters, and using print in many different ways. If your child is interested, you might consider doing some of the following activities together:

- Make a word box and encourage your child to add to it words cut from labels, flyers, etc., that s/he can read.
- Make stick puppets and use them to act out familiar stories or stories that you make up.
- Make a book of family stories and events.
- Make lists, such as shopping lists, task lists, or lists of favourite books.
- Tell each other stories. You could start by telling a favourite story you know or a story about when you were young.
- Invite your child to help you use print to complete tasks, such as following a map or choosing from a menu.
- Go on a "scavenger hunt" for different letters of the alphabet.
- Recite favourite chants and songs.

As well, if you have a story or book that you think other children would enjoy, please let me know. We can make arrangements for sharing it with the class.

Finger Puppets

Line Master 2

1. Print and cut out the animals with scissors.
2. Wrap the tabs around a finger and tape securely.

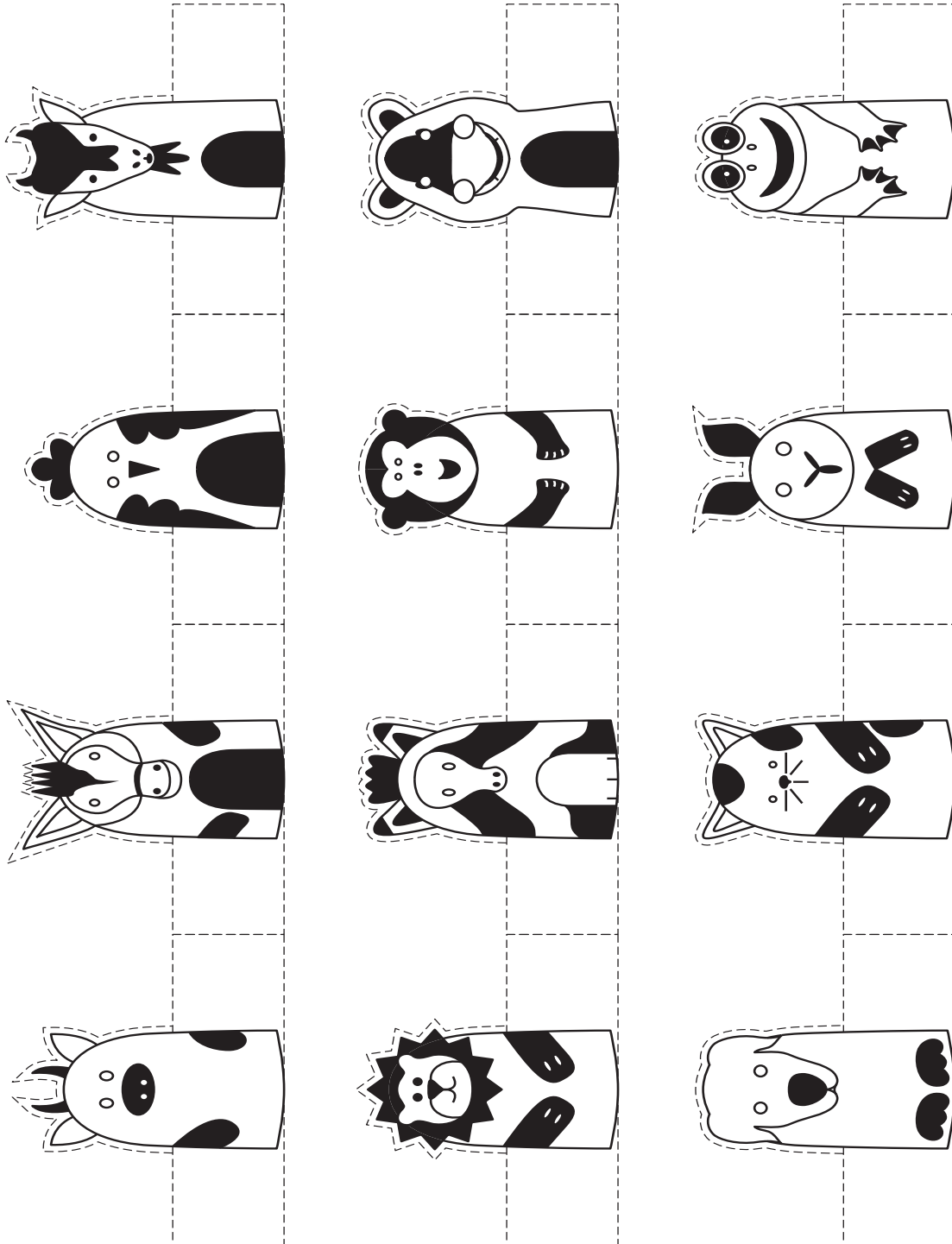

Lower Case Letters (a-o)

Line Master 3

a

b

c

d

e

f

g

h

i

j

k

l

m

n

o

Lower Case Letters (p-z)

Line Master 4

p	q	r
s	t	u
v	w	x
y	z	

Upper Case Letters (A–O)

Line Master 5

A

B

C

D

E

F

G

H

I

J

K

L

M

N

O

Upper Case Letters (P-Z)

Line Master 6

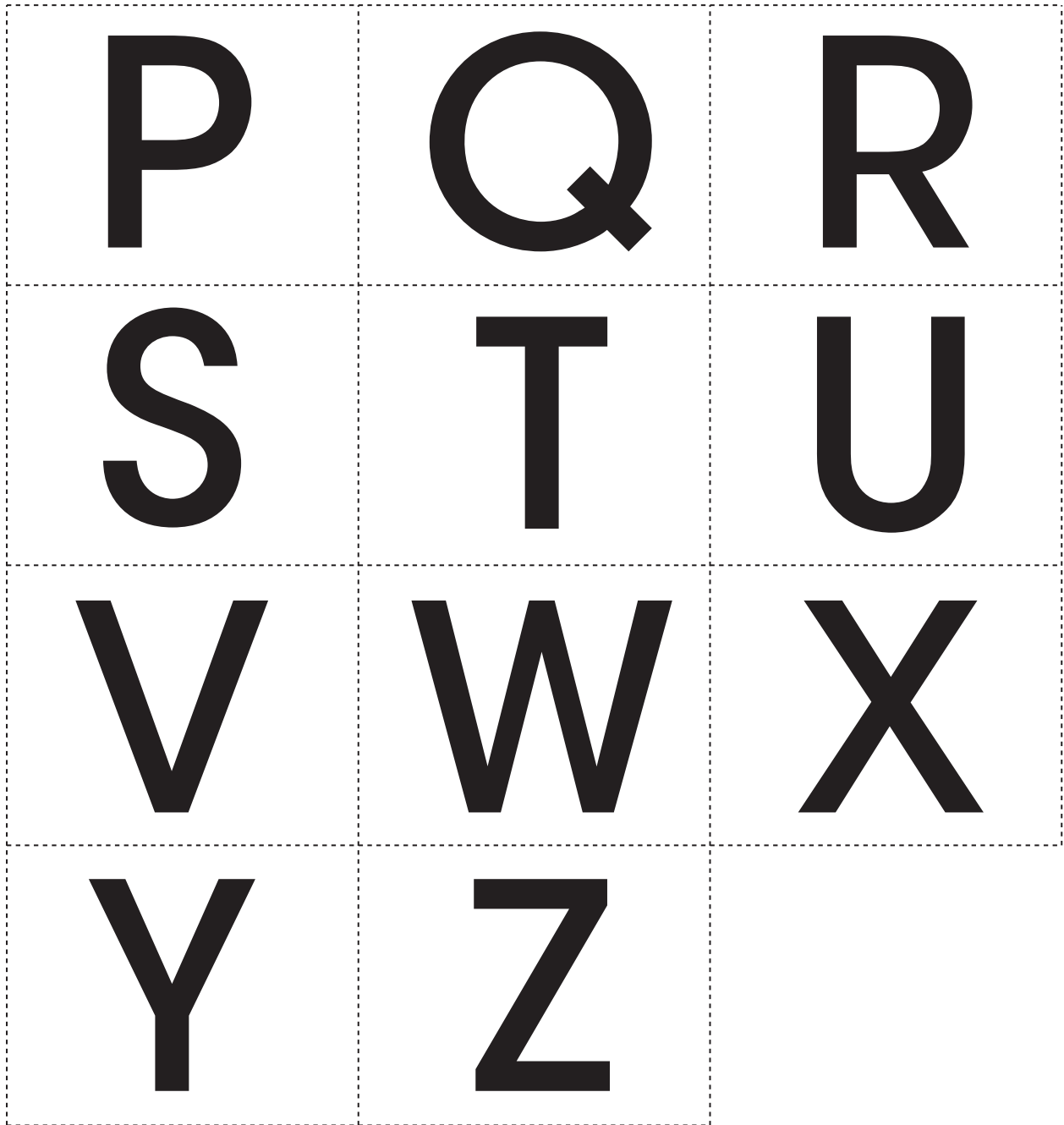

Graphing Mat (2 columns)

Line Master 7

--

--

Graphing Mat (3 columns)

--	--	--

Graphing Mat (6 columns)

--	--	--	--	--	--

Please feel free to modify this text to make the letter your own.

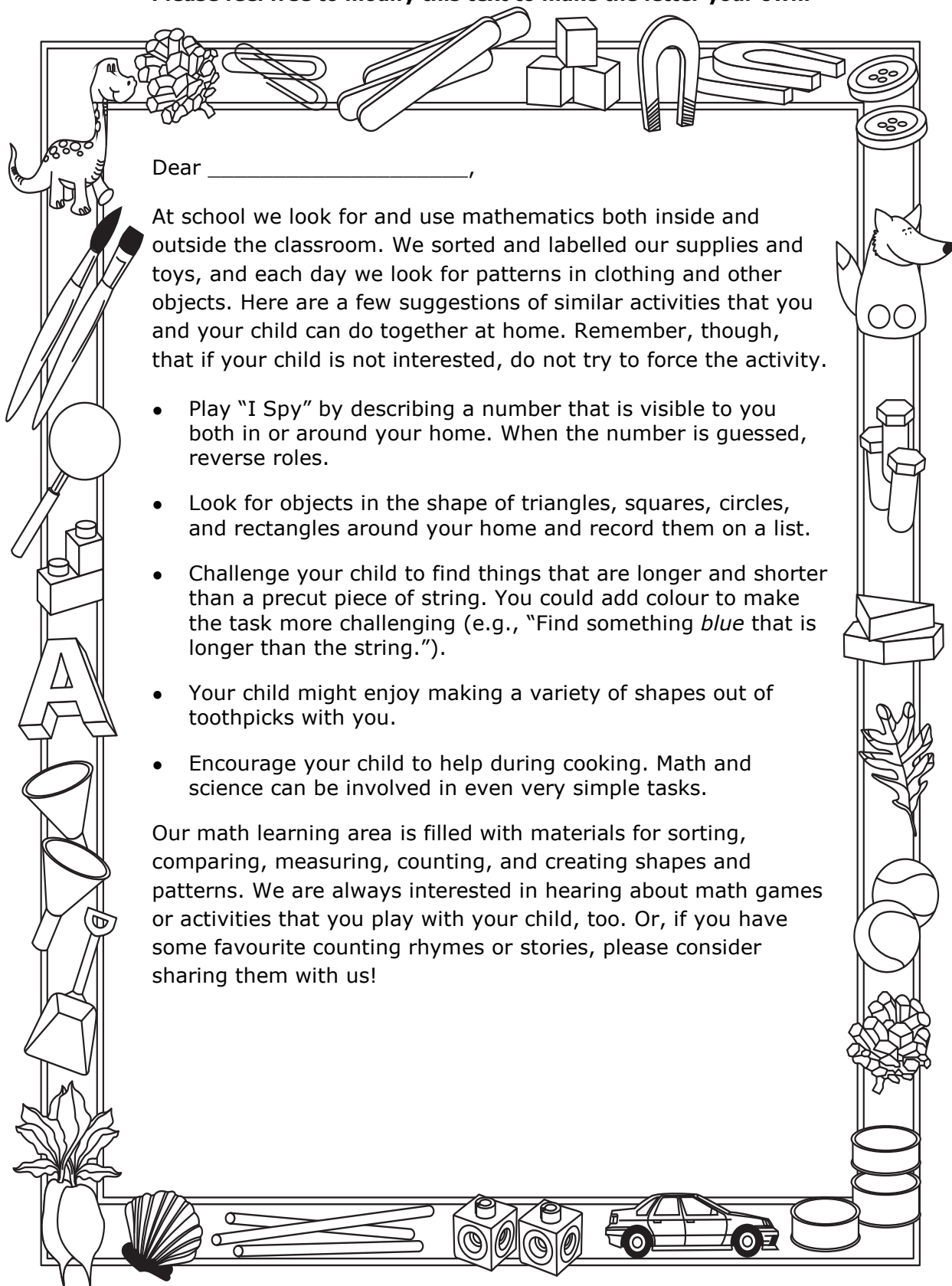

Dear _____,

At school we look for and use mathematics both inside and outside the classroom. We sorted and labelled our supplies and toys, and each day we look for patterns in clothing and other objects. Here are a few suggestions of similar activities that you and your child can do together at home. Remember, though, that if your child is not interested, do not try to force the activity.

- Play "I Spy" by describing a number that is visible to you both in or around your home. When the number is guessed, reverse roles.
- Look for objects in the shape of triangles, squares, circles, and rectangles around your home and record them on a list.
- Challenge your child to find things that are longer and shorter than a precut piece of string. You could add colour to make the task more challenging (e.g., "Find something *blue* that is longer than the string.").
- Your child might enjoy making a variety of shapes out of toothpicks with you.
- Encourage your child to help during cooking. Math and science can be involved in even very simple tasks.

Our math learning area is filled with materials for sorting, comparing, measuring, counting, and creating shapes and patterns. We are always interested in hearing about math games or activities that you play with your child, too. Or, if you have some favourite counting rhymes or stories, please consider sharing them with us!

My Sorting

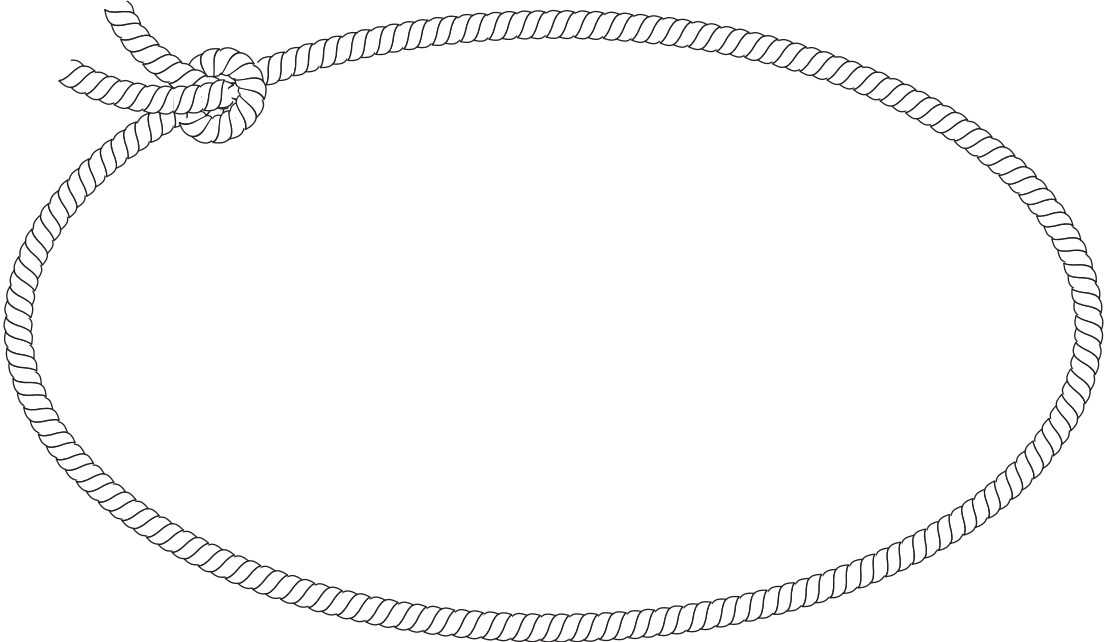
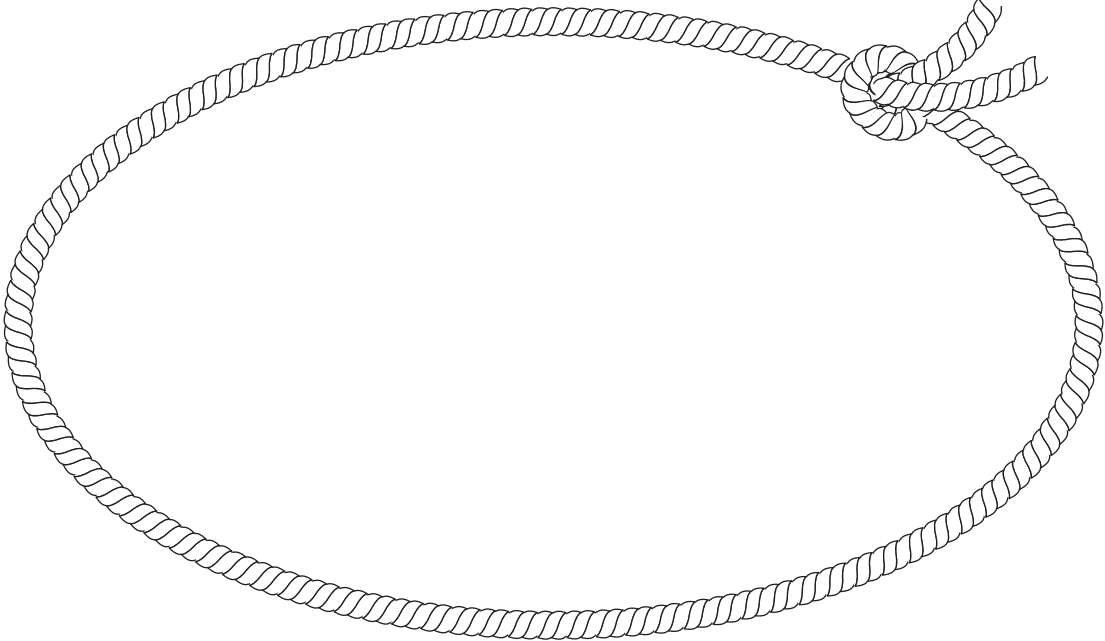

Ordering Mat

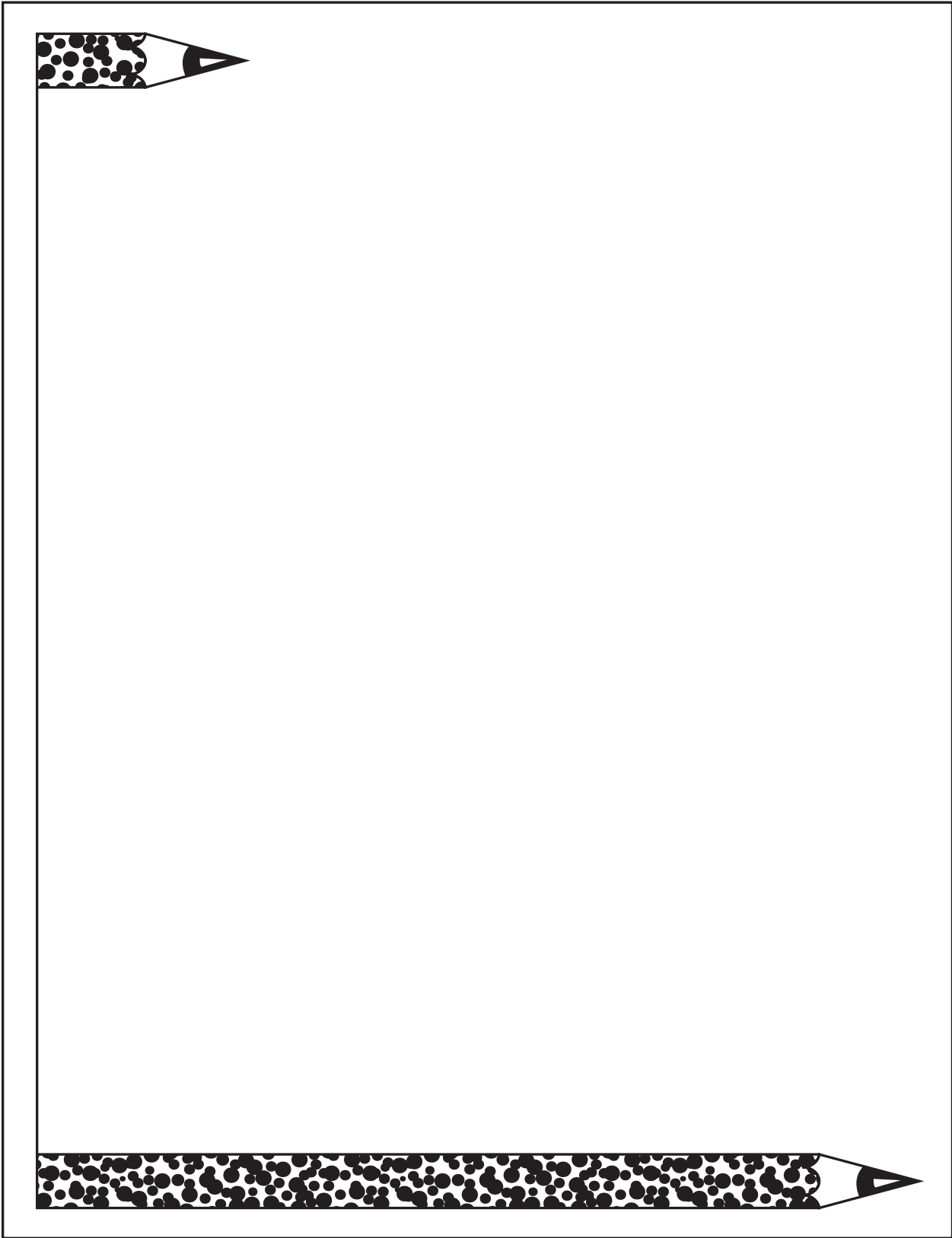



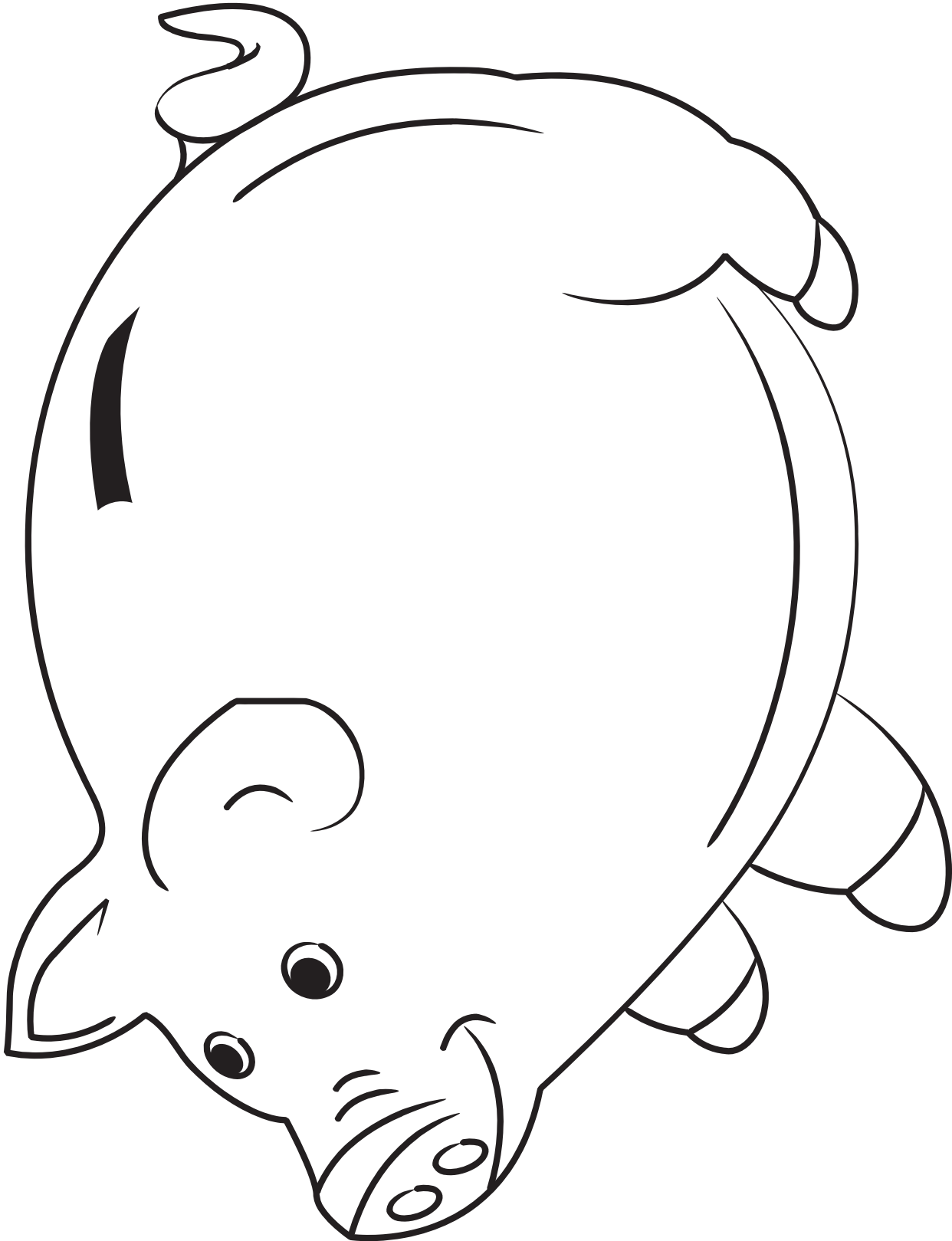

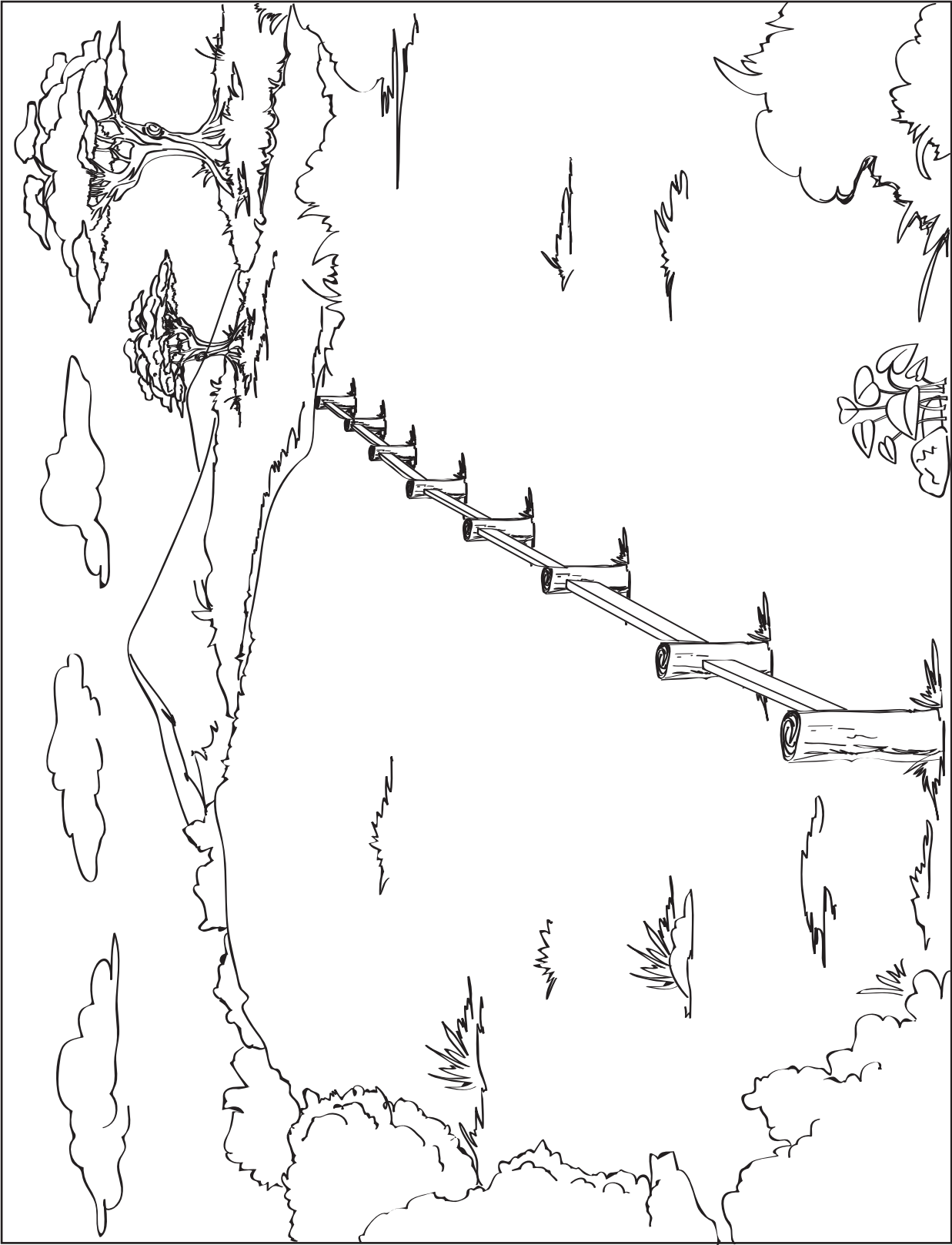

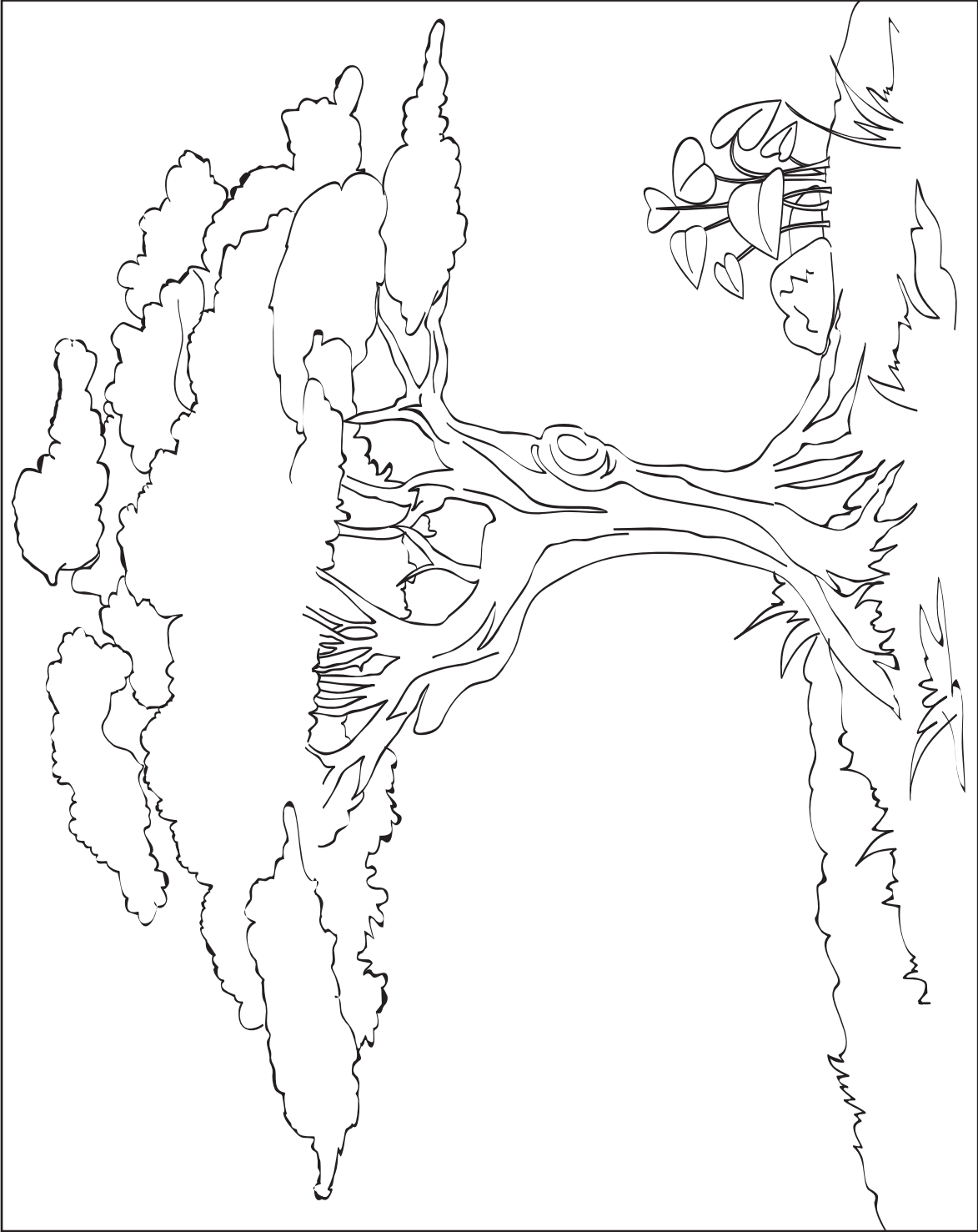

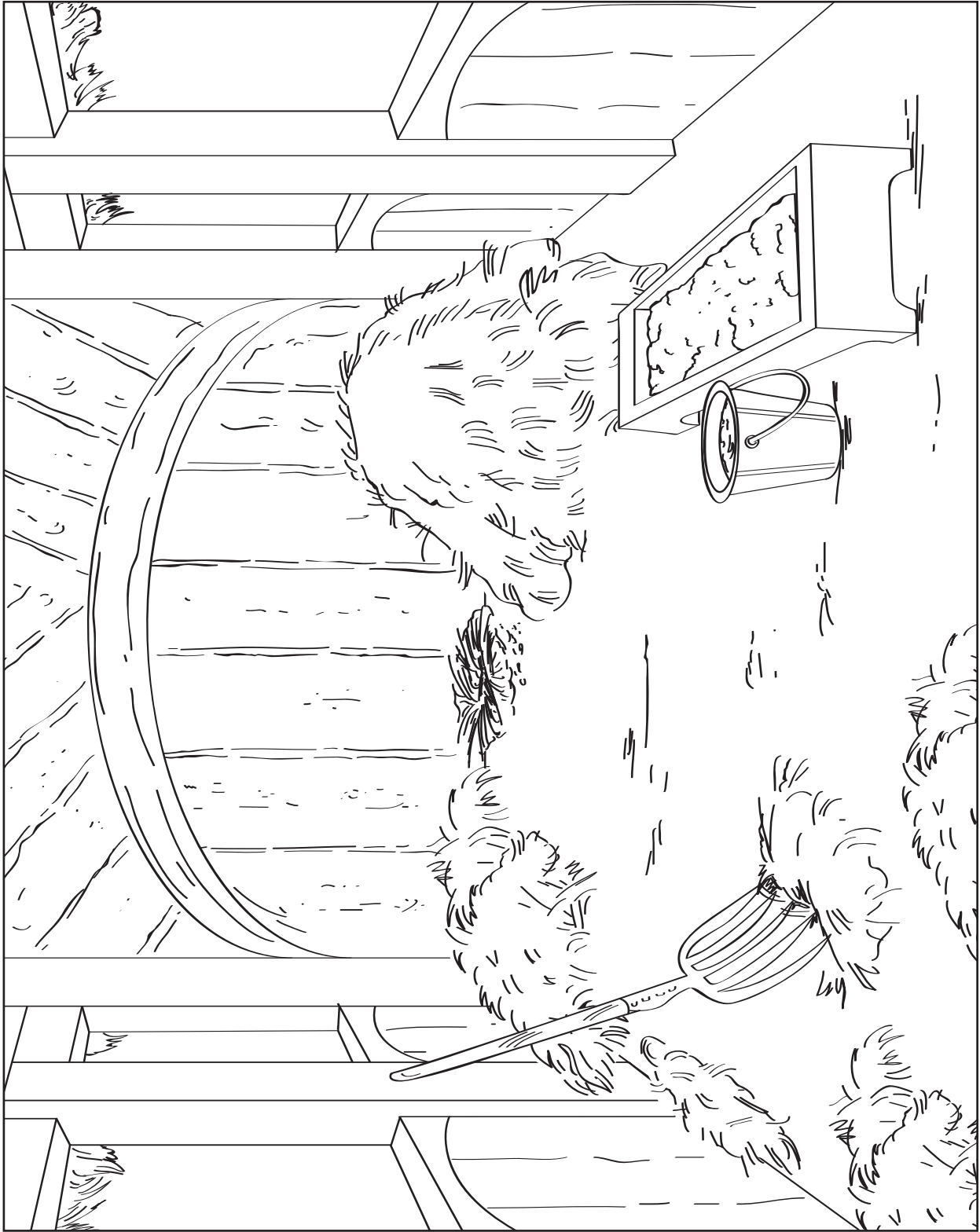

Castle Storyboard

Line Master 18

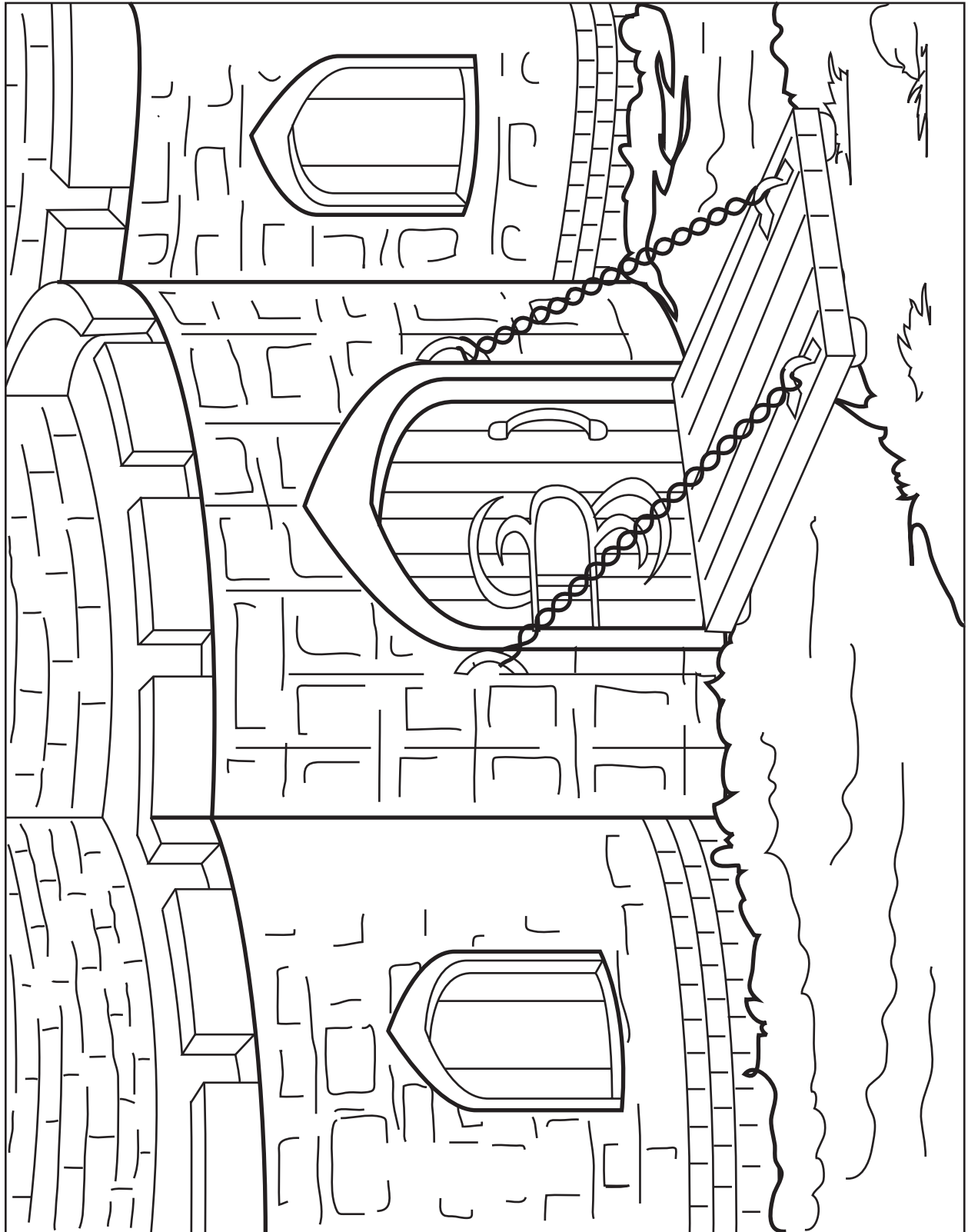

Numeral Cards (small)

Line Master 19

0

1

2

3

4

5

6

7

8

9

10

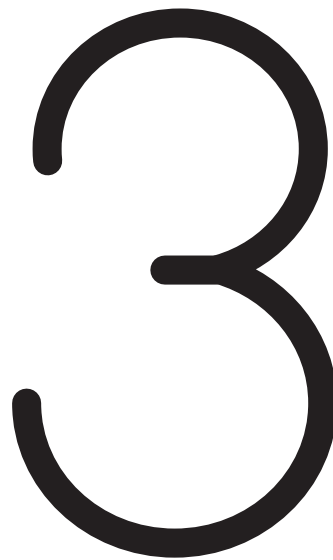
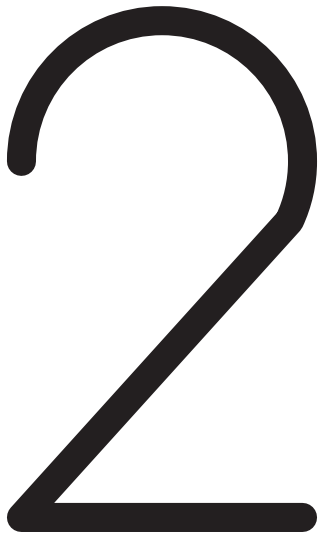
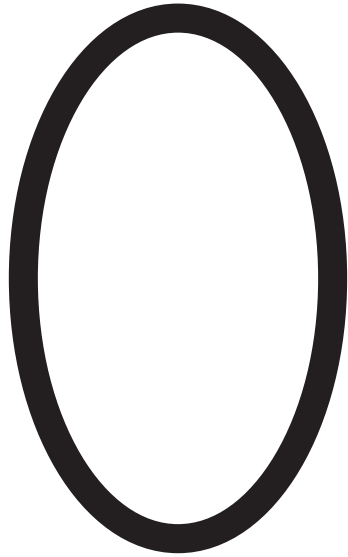

4

5

6

7

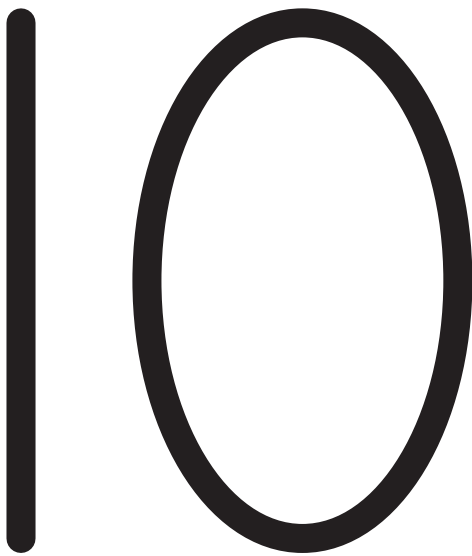
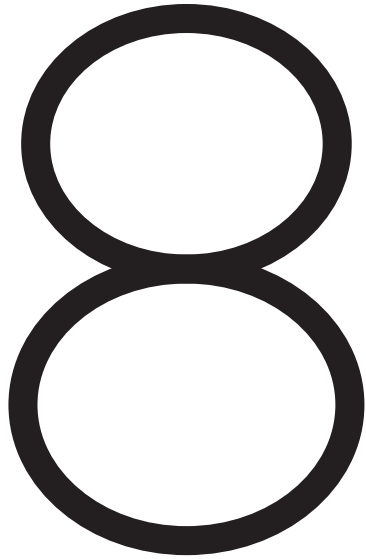

5-Frame Grids

Interlocking Cubes

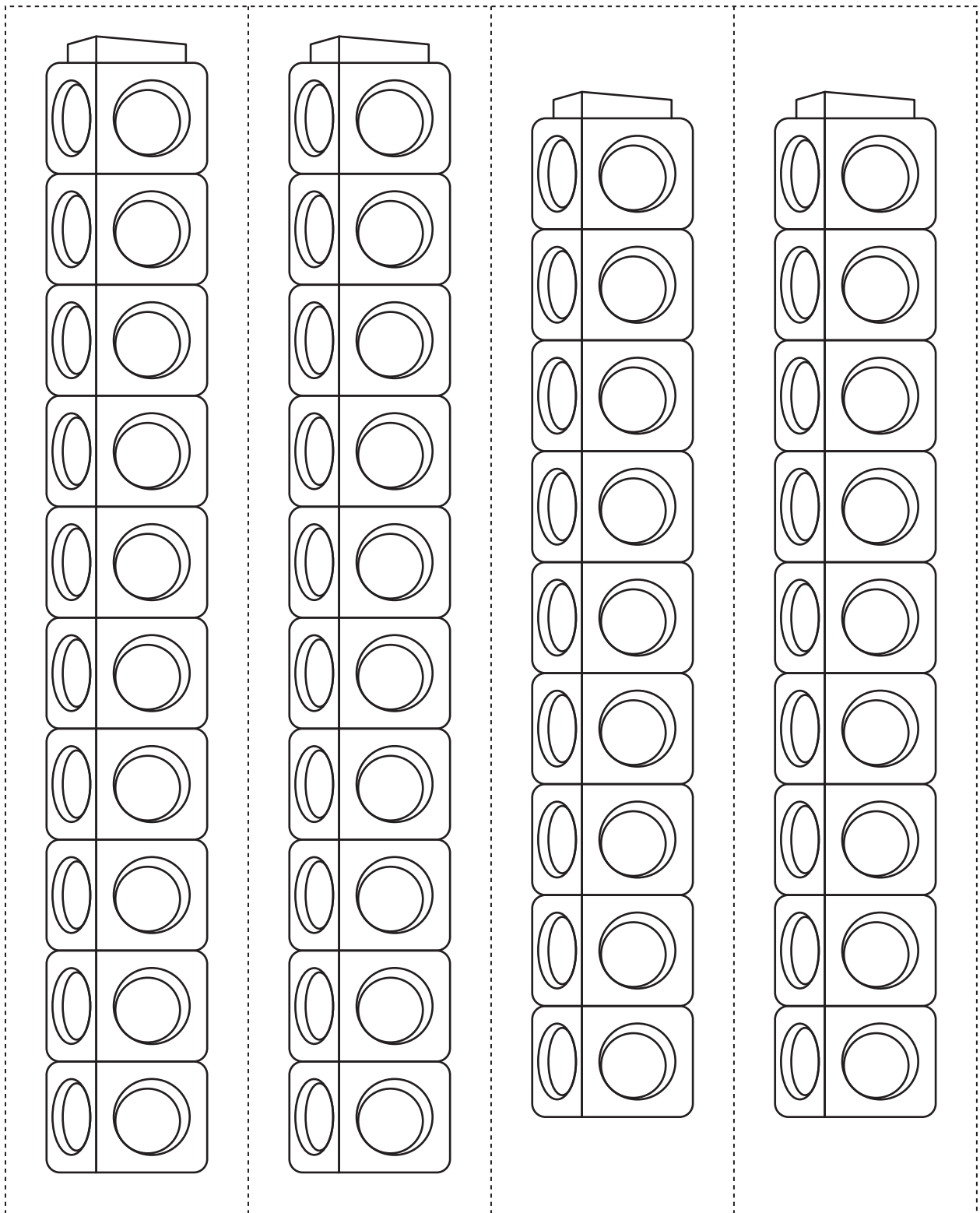

Pattern Strips 1

Line Master 25

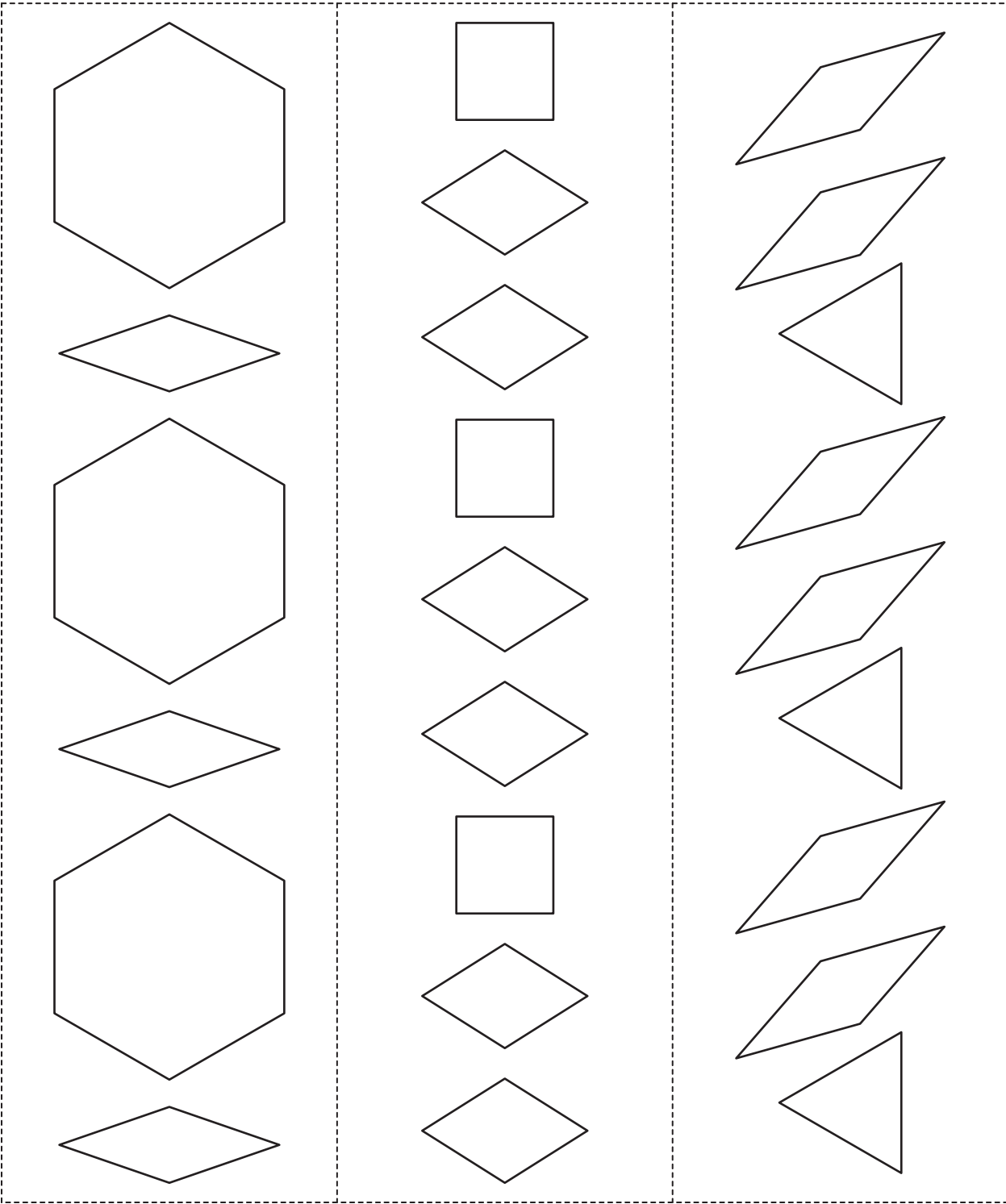



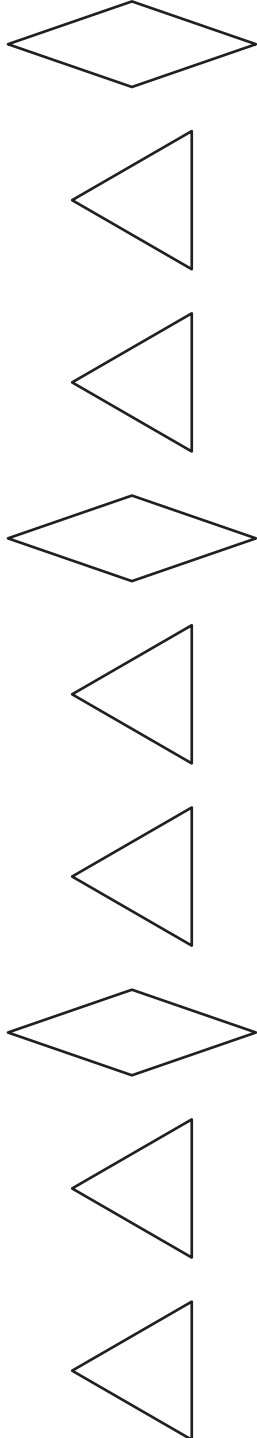
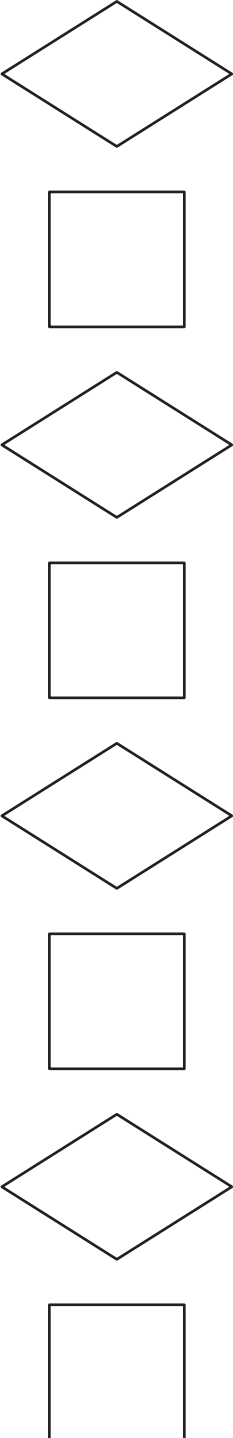
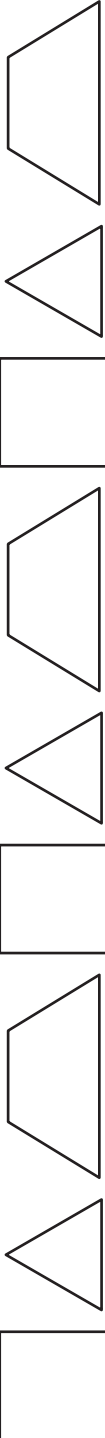
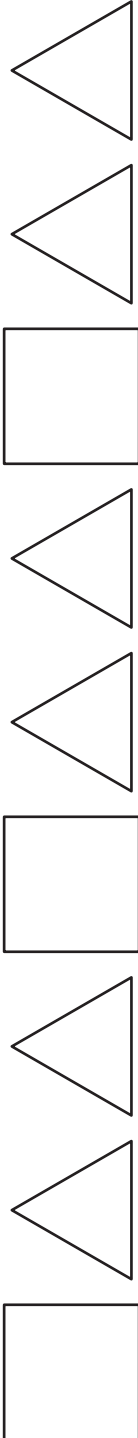

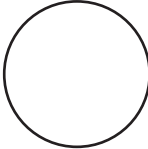
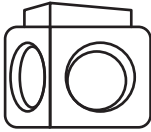
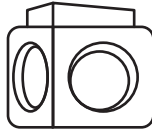
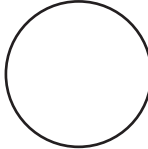
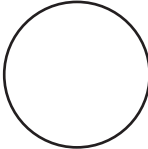
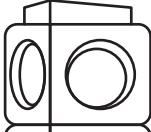
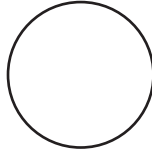
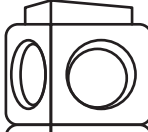
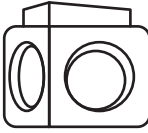
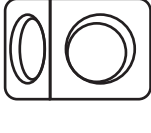
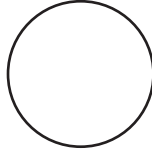
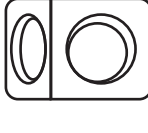
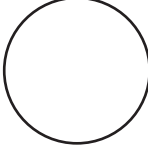
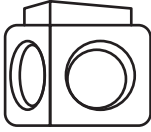
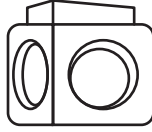
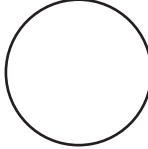
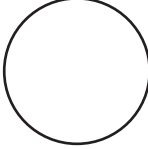
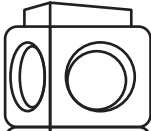
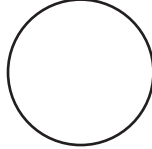
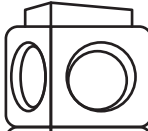
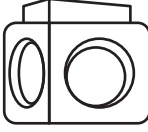
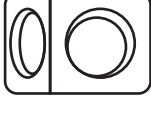
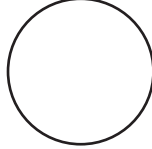

Pattern Strips 2

			
--	--	---	--

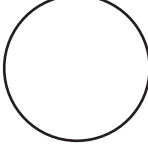
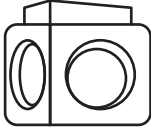
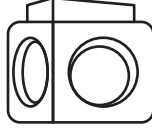
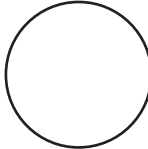
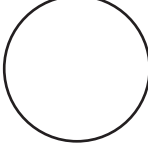
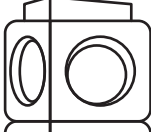
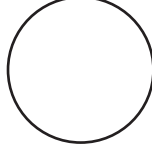
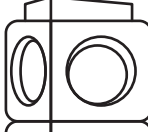
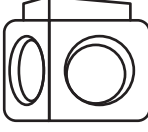
Pattern Strips 3

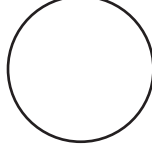
Line Master 27

Pattern Strips 4

Line Master 28

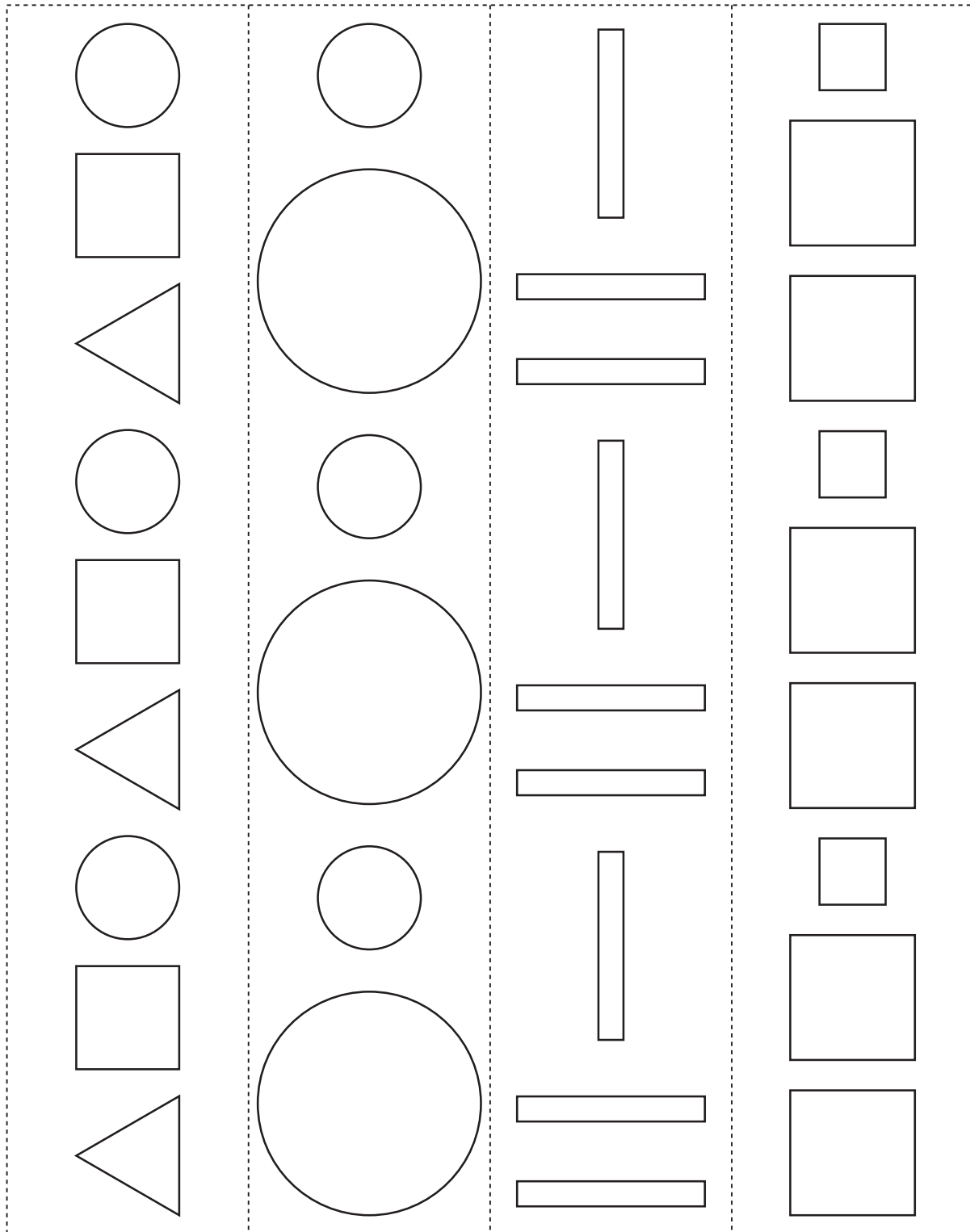

Note: You may wish to print on **orange** paper.

Square Pattern Blocks

Note: You may wish to print on **orange** paper.

Triangle Pattern Blocks

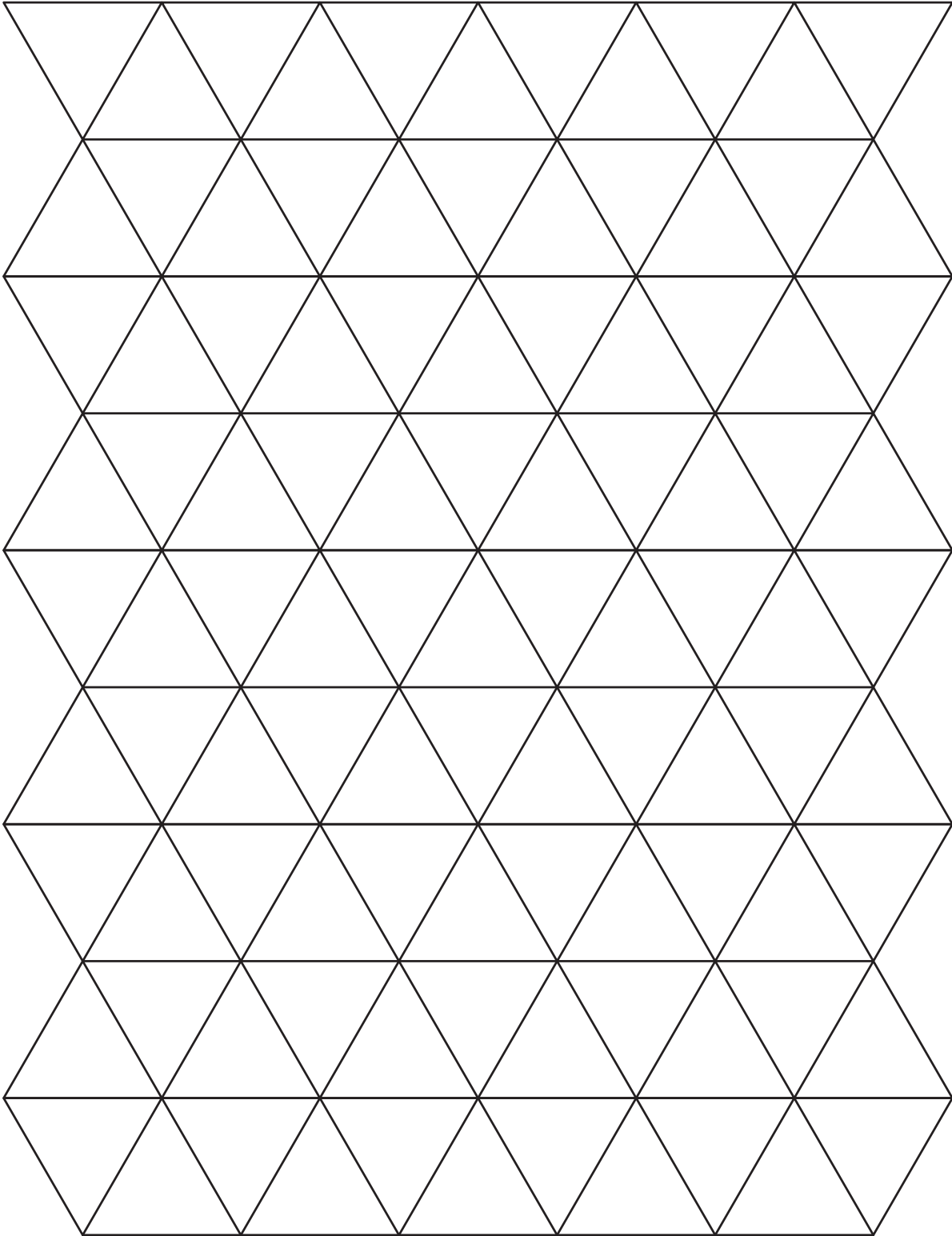

Note: You may wish to print on **green** paper.

Diamond Pattern Blocks (small)

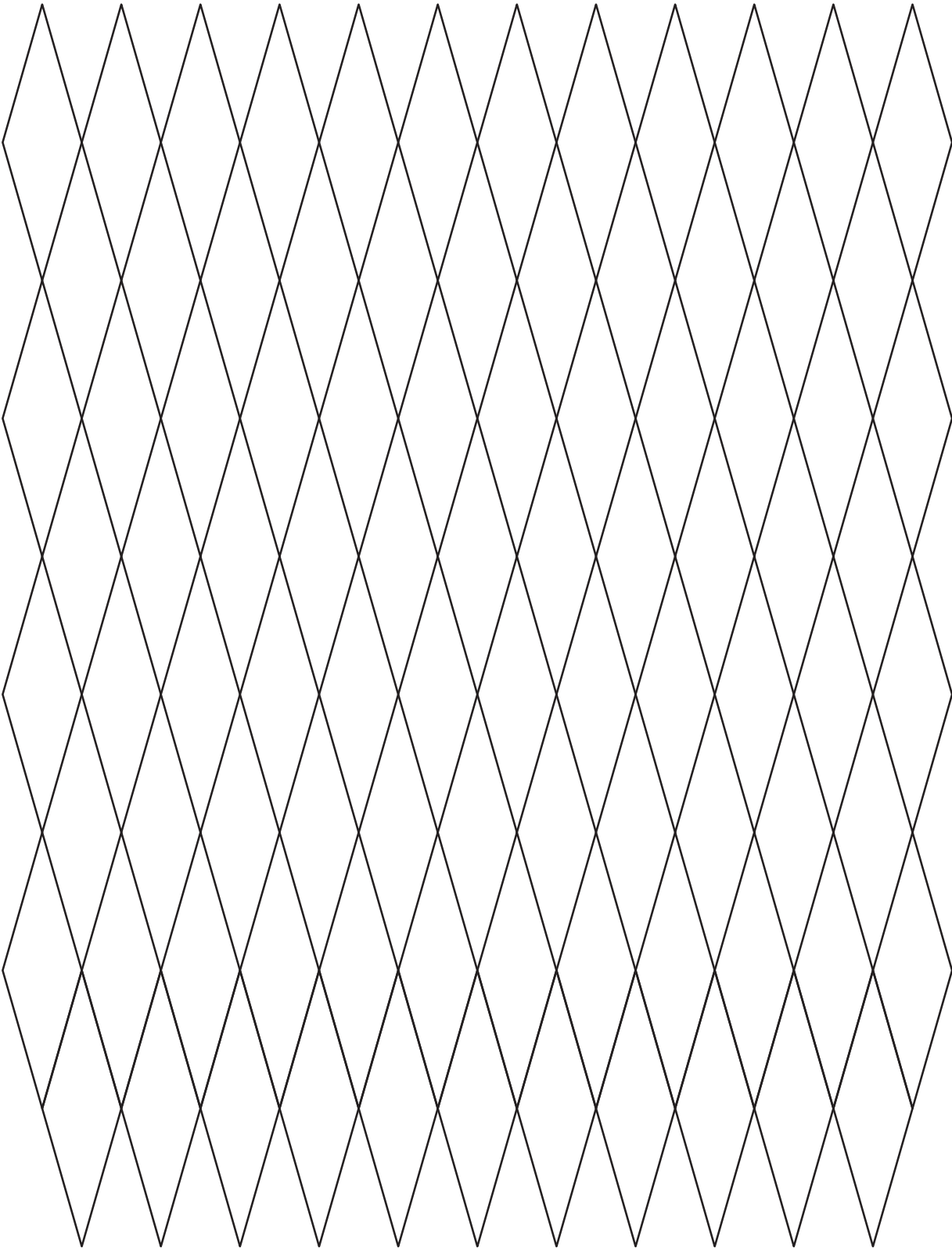

Note: You may wish to print on **tan** paper.

Diamond Pattern Blocks (large)

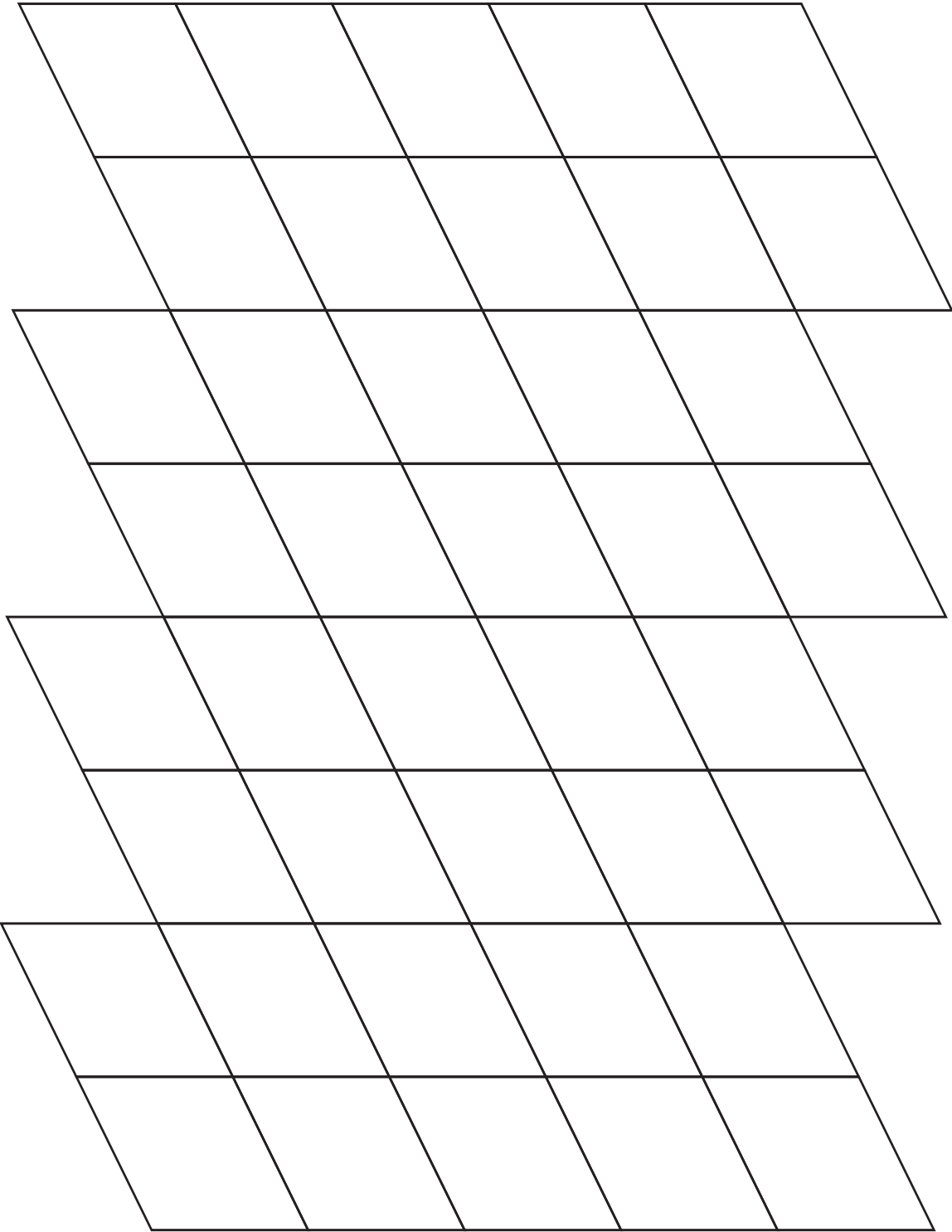

Note: You may wish to print on **blue** paper.

Trapezoid Pattern Blocks

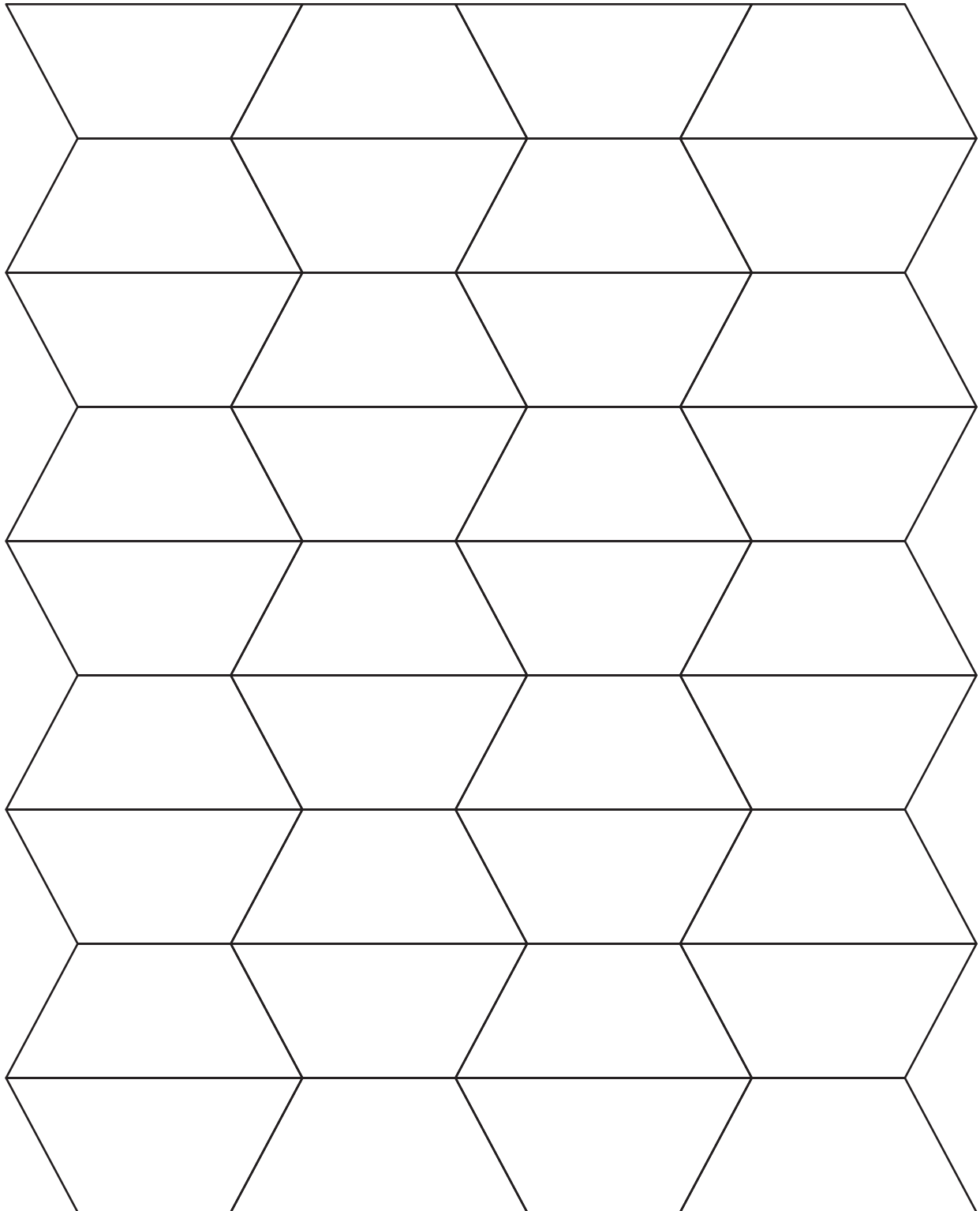

Note: You may wish to print on **red** paper.

Hexagon Pattern Blocks

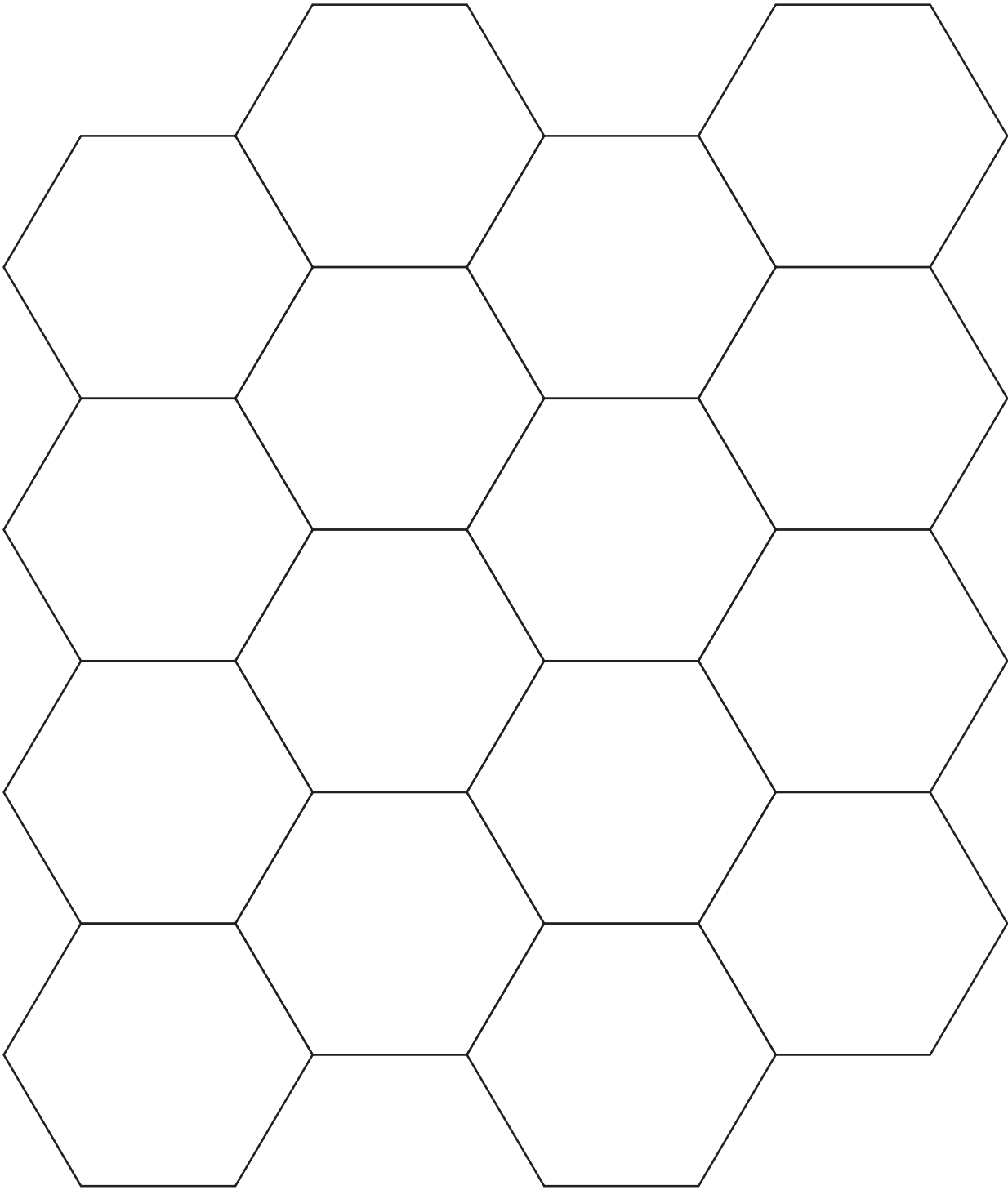

Note: You may wish to print on **yellow** paper.

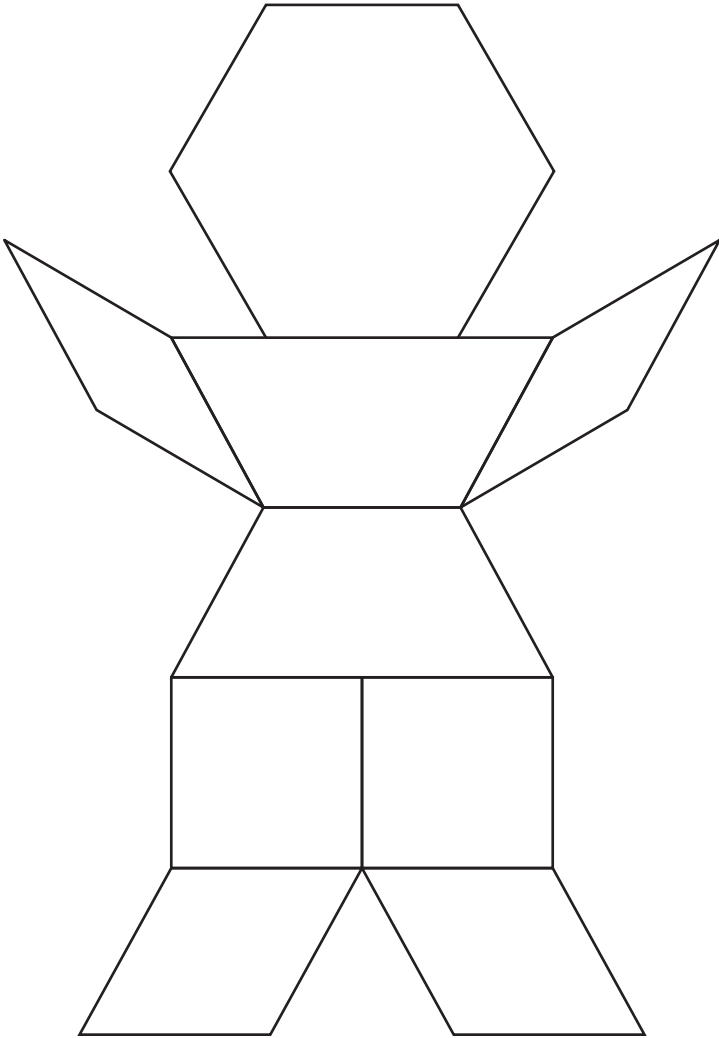

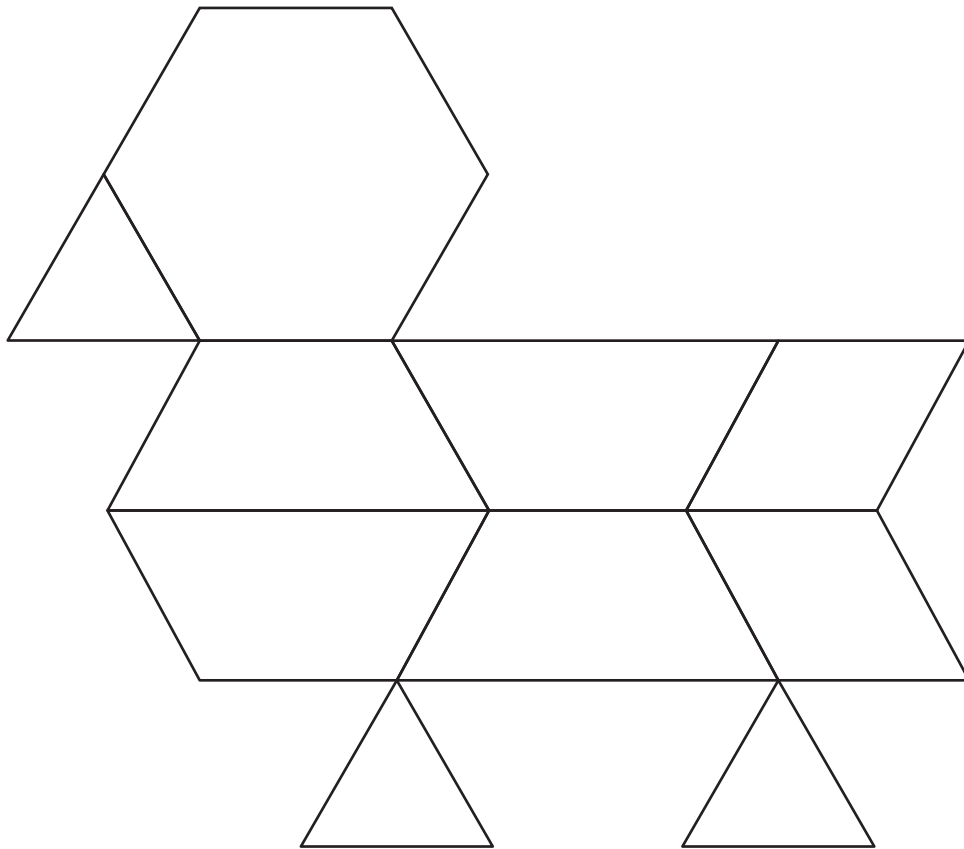
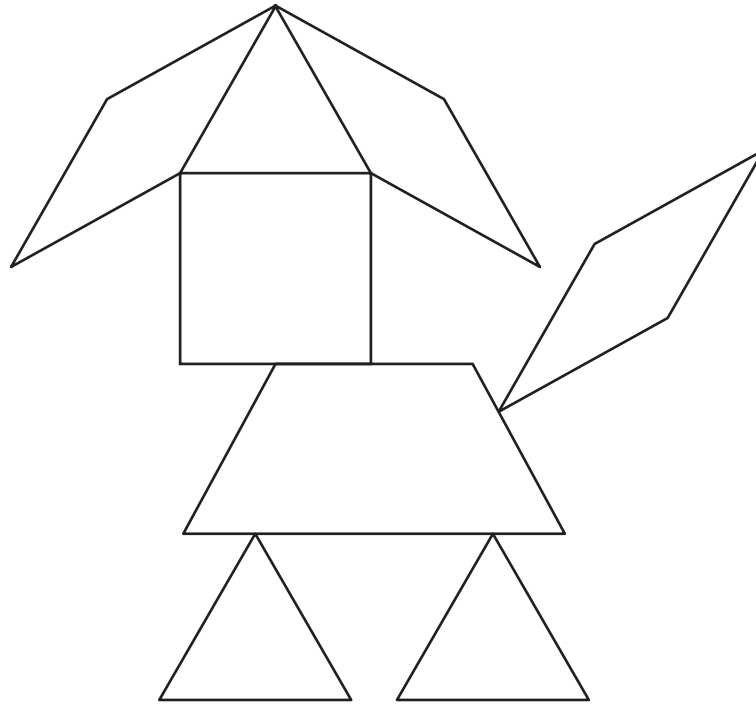

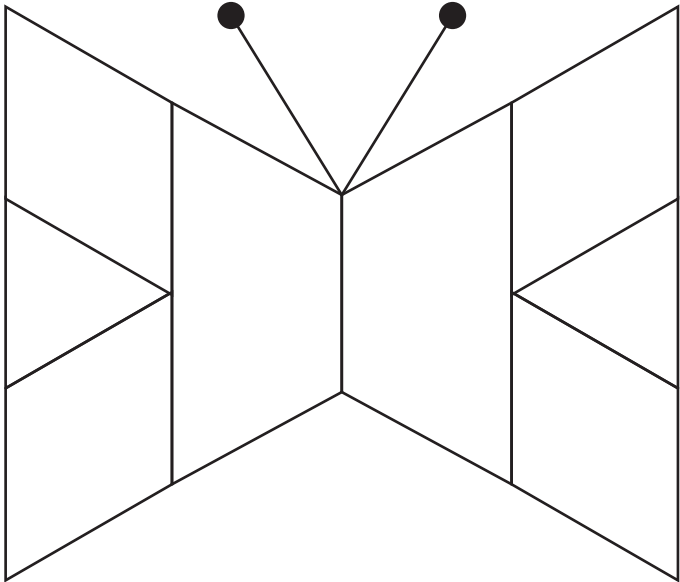
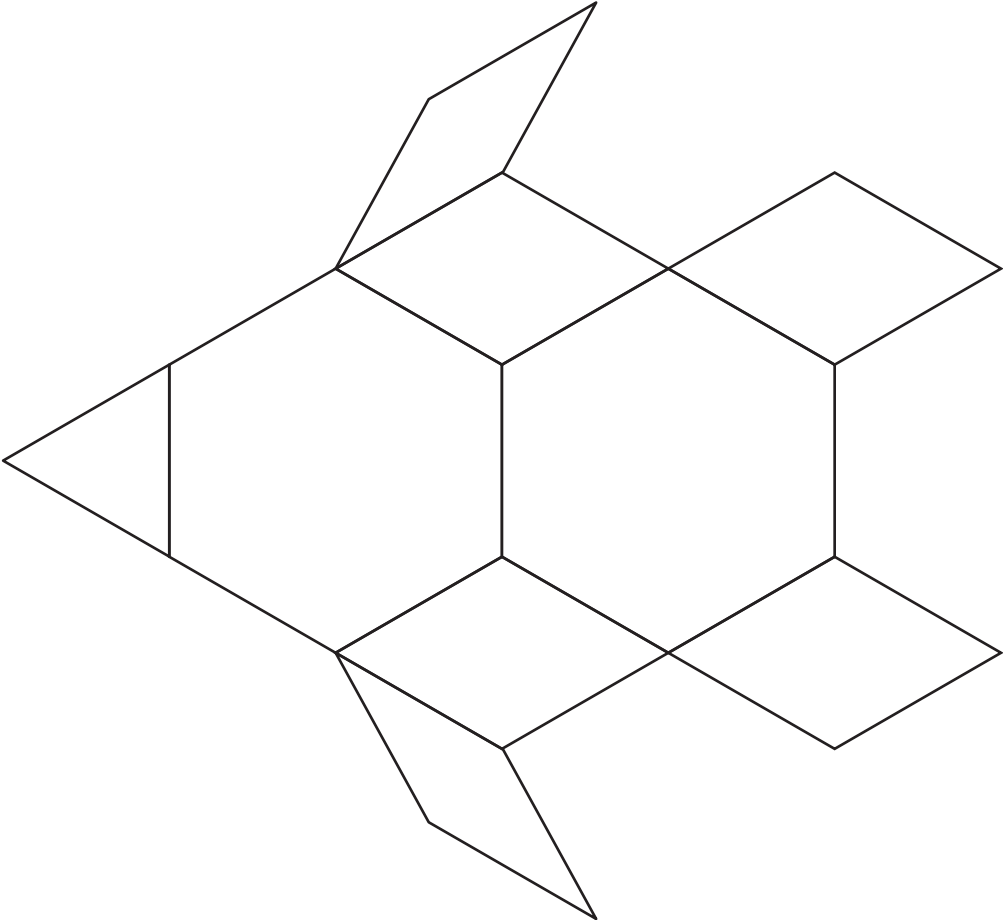

Fill and Spill (3 counters)

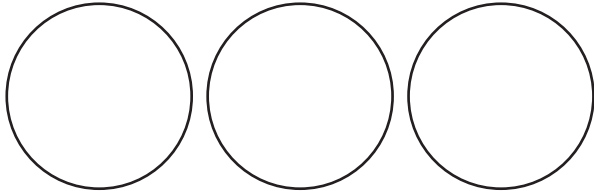
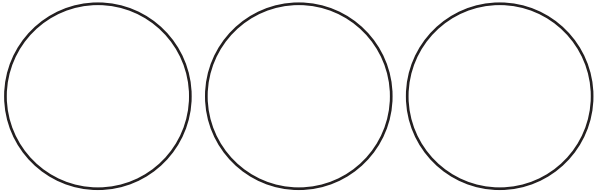
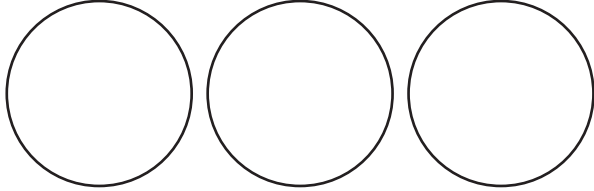
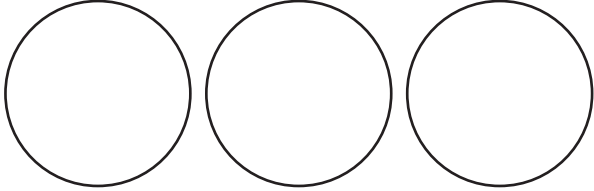
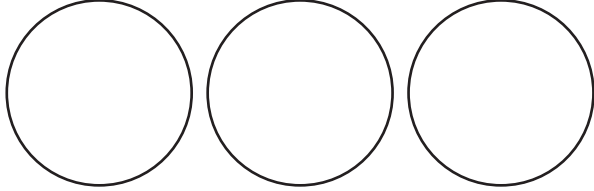
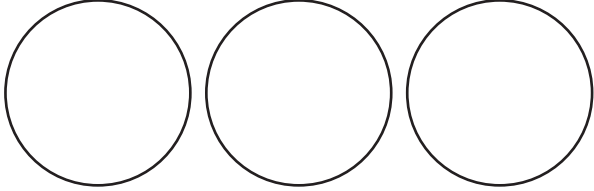
Fill and Spill (4 counters)

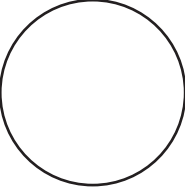
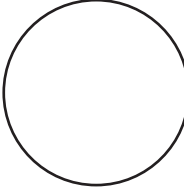
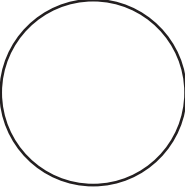
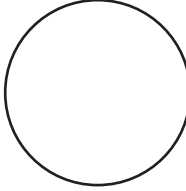
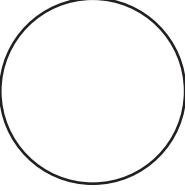
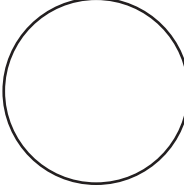
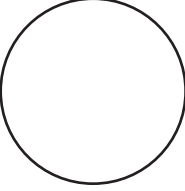
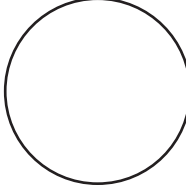
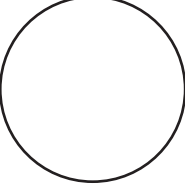
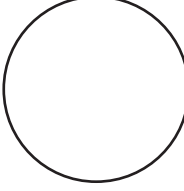
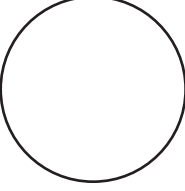
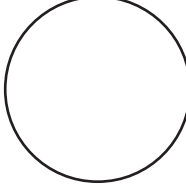
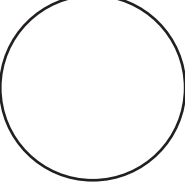
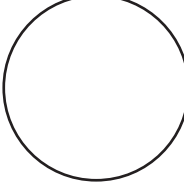
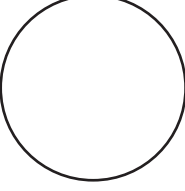
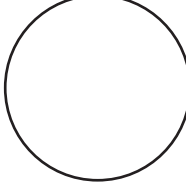
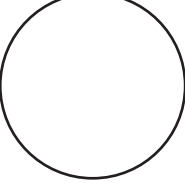
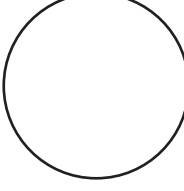
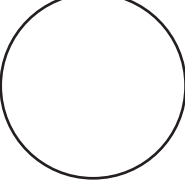
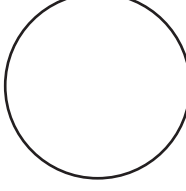
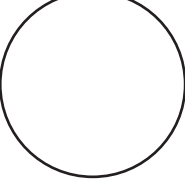
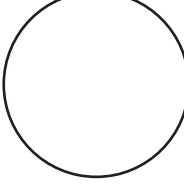
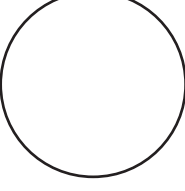
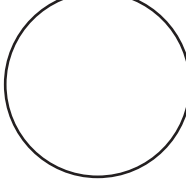

Fill and Spill (5 counters)

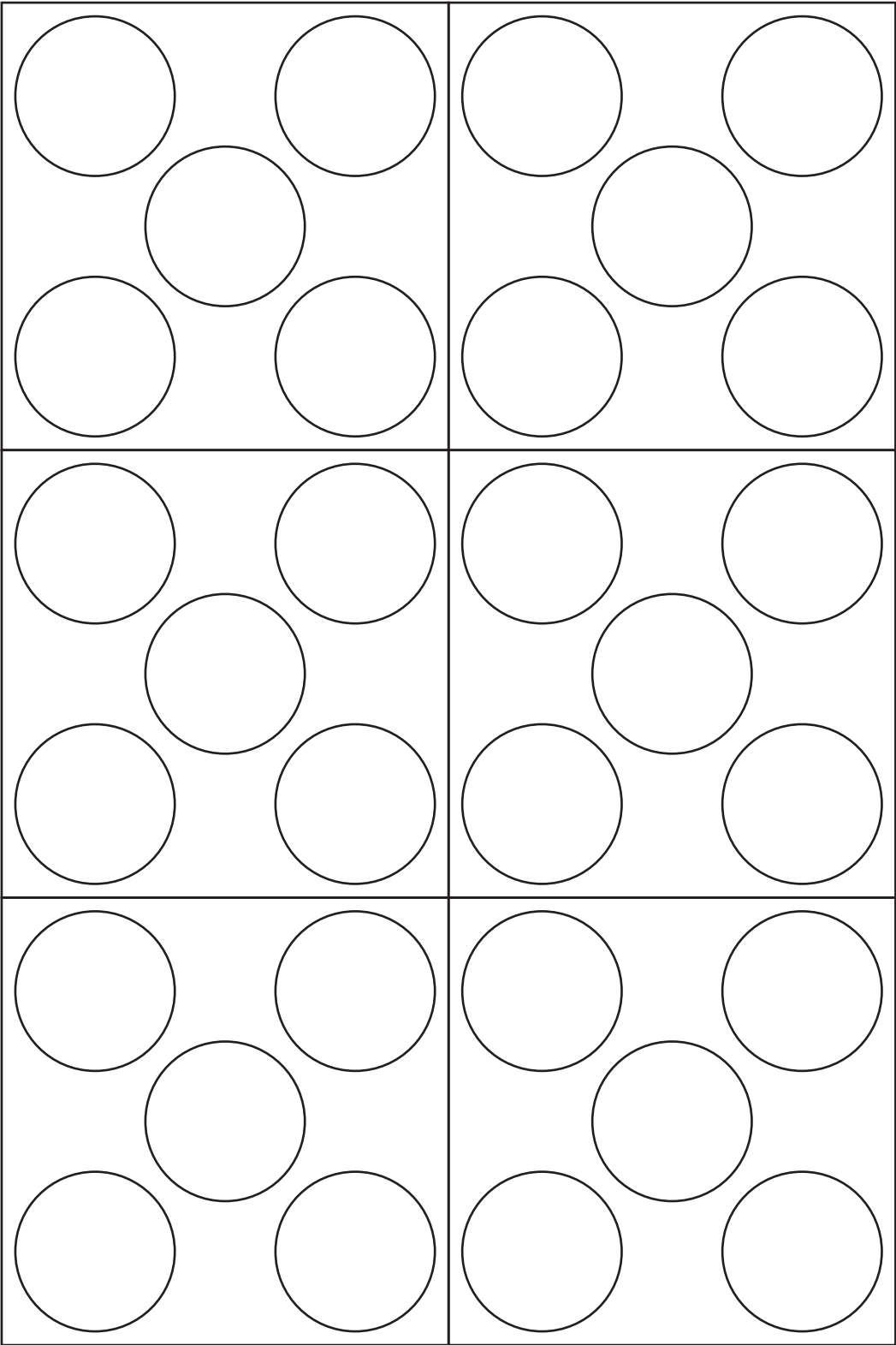

Fill and Spill (6 counters)

Line Master 41

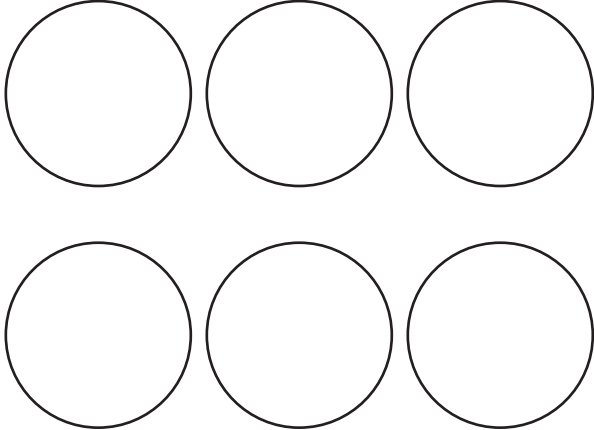
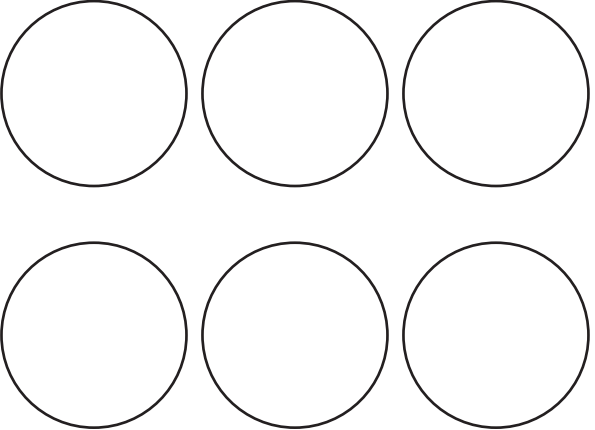
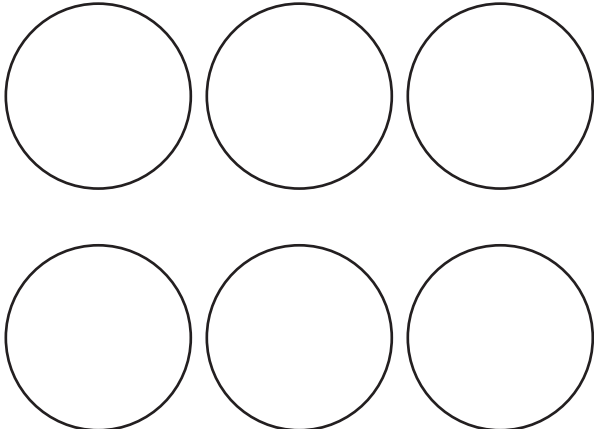
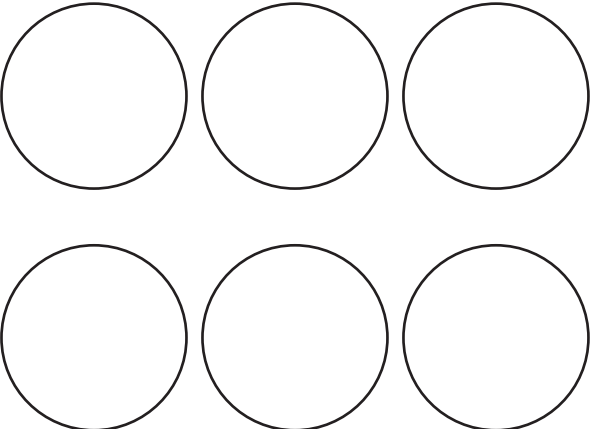
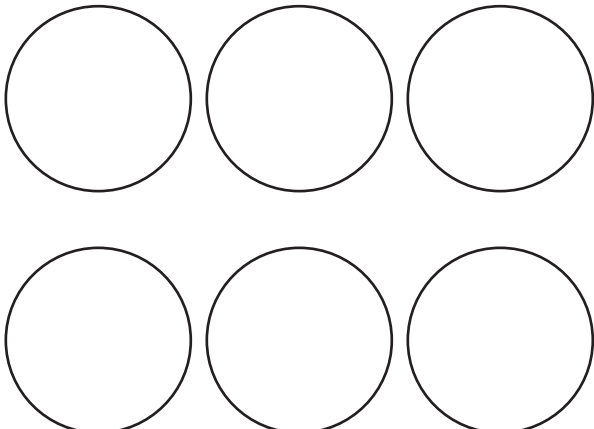
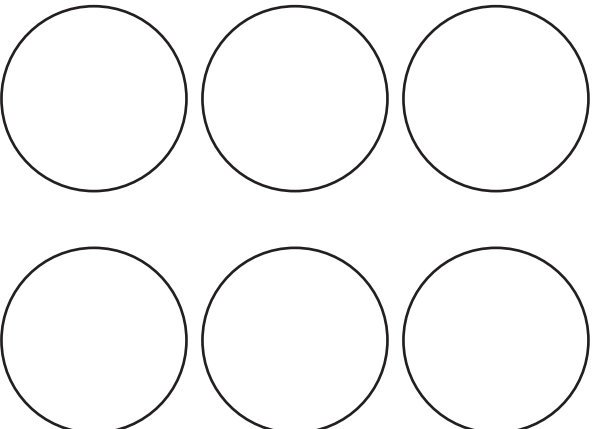

Dot Configurations 1

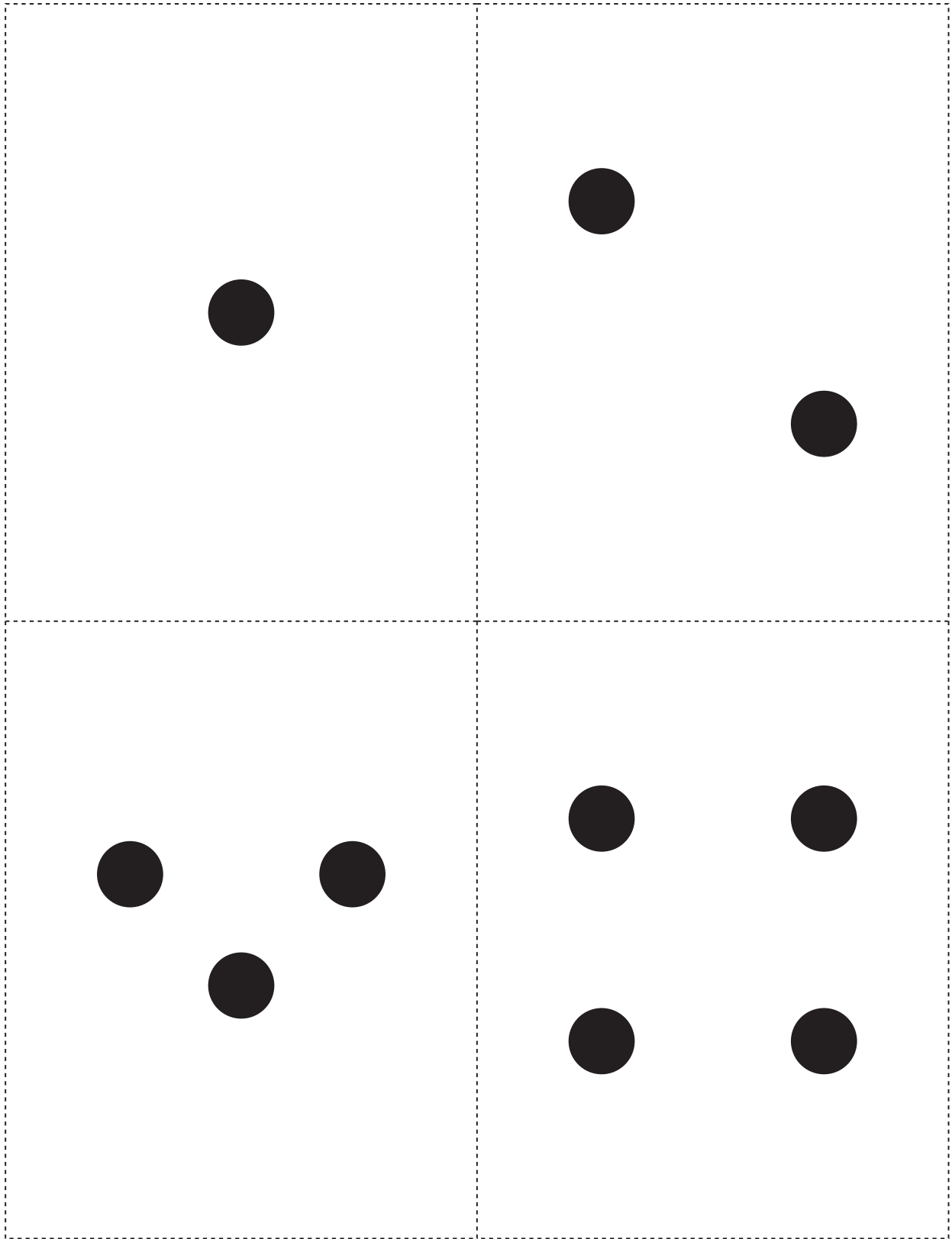

Dot Configurations 2

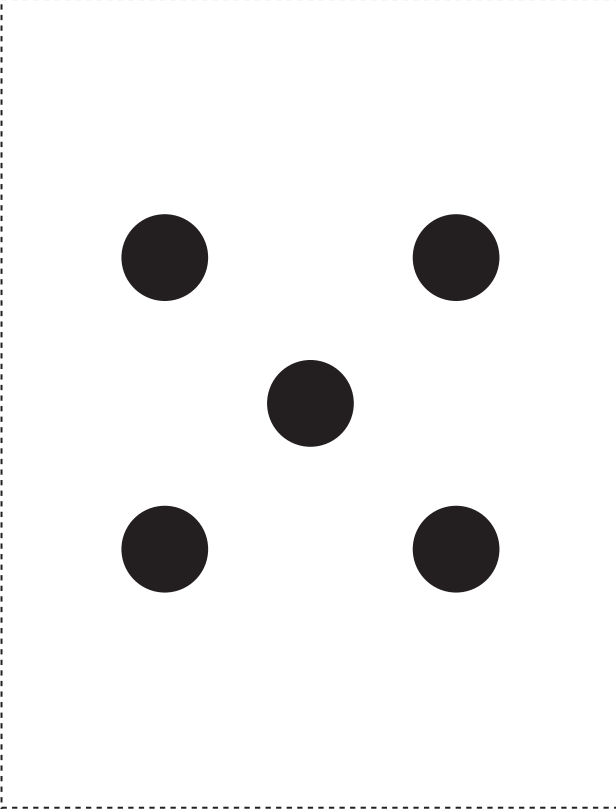
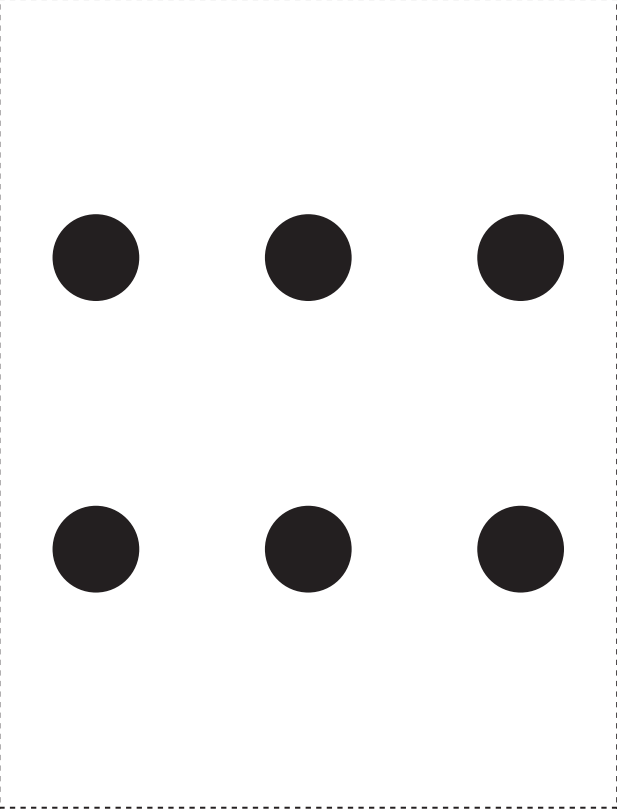
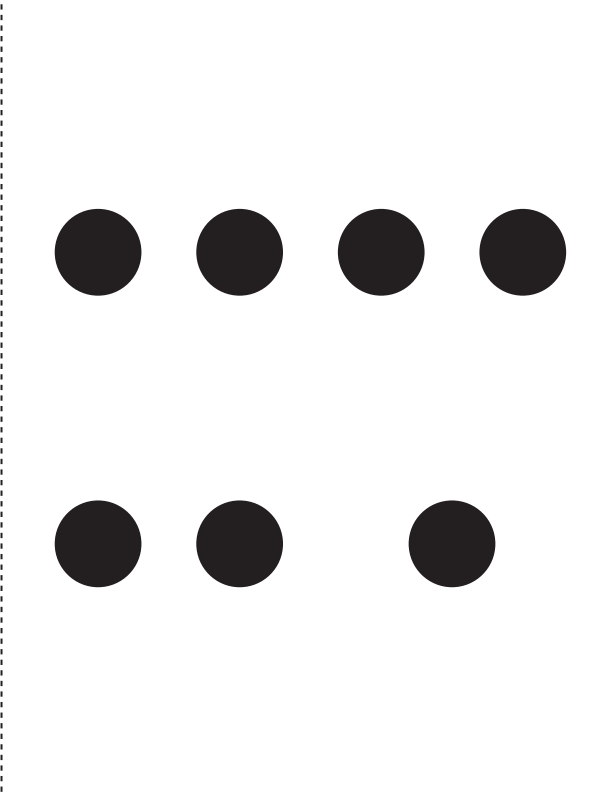
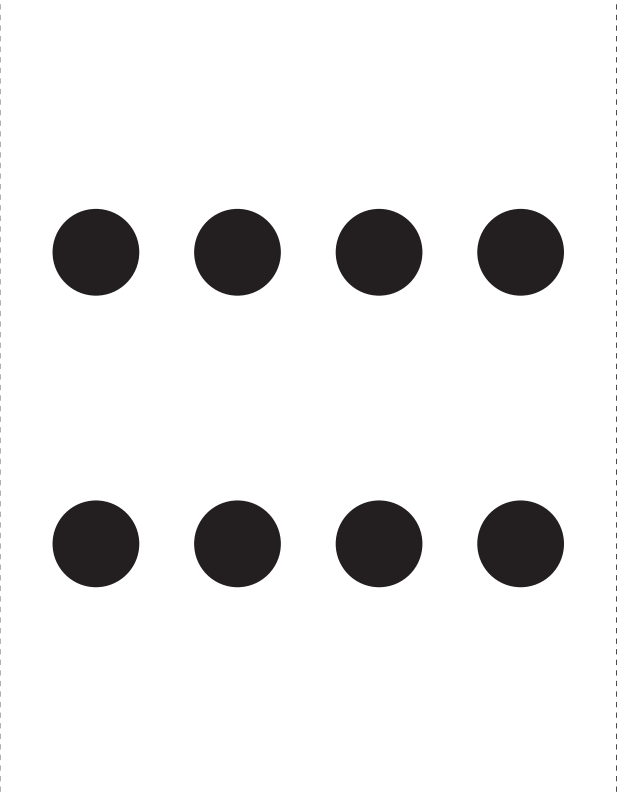
 <p>A 3x2 grid of dots. The top row has two dots. The middle row has one dot centered between the two columns. The bottom row has two dots.</p>	 <p>A 2x3 grid of dots. The top row has three dots. The bottom row has three dots.</p>
 <p>A 2x4 grid of dots. The top row has four dots. The bottom row has three dots.</p>	 <p>A 2x4 grid of dots. The top row has four dots. The bottom row has four dots.</p>

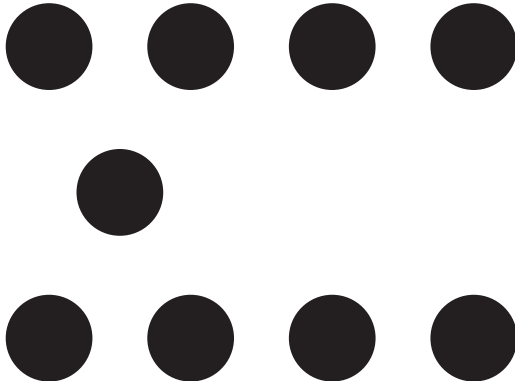
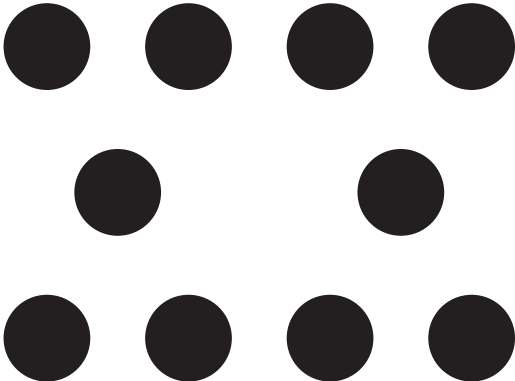
Dot Configurations 3

The image shows a large rectangle divided into four quadrants by dashed lines. Each quadrant contains a set of black dots:

- Top-left: Three dots in a horizontal row.
- Top-right: Five dots arranged in a descending staircase pattern from top-left to bottom-right.
- Bottom-left: Five dots arranged in two rows: three in the top row and two in the bottom row.
- Bottom-right: Six dots arranged in two rows of three dots each.

Dot Configurations 5

Staircase Grid

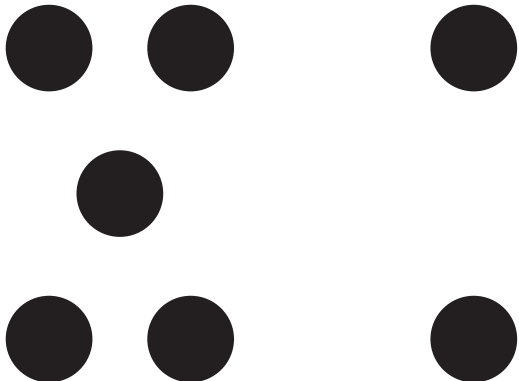
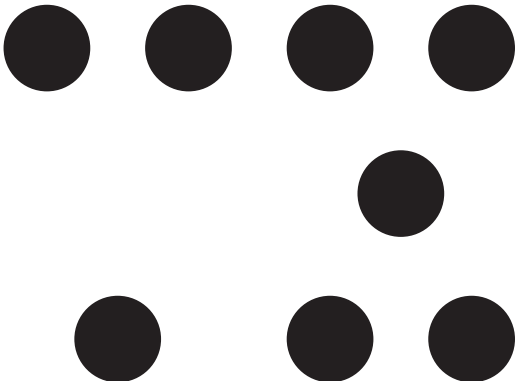
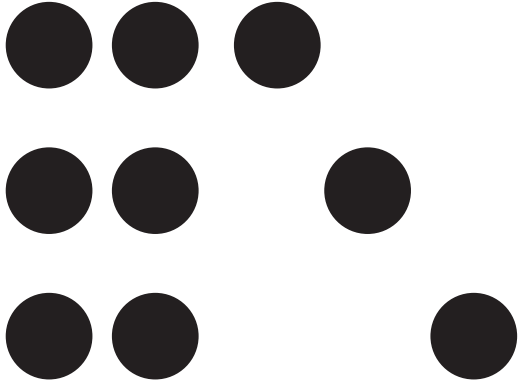
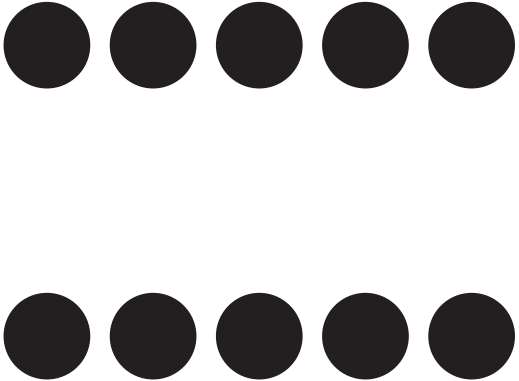

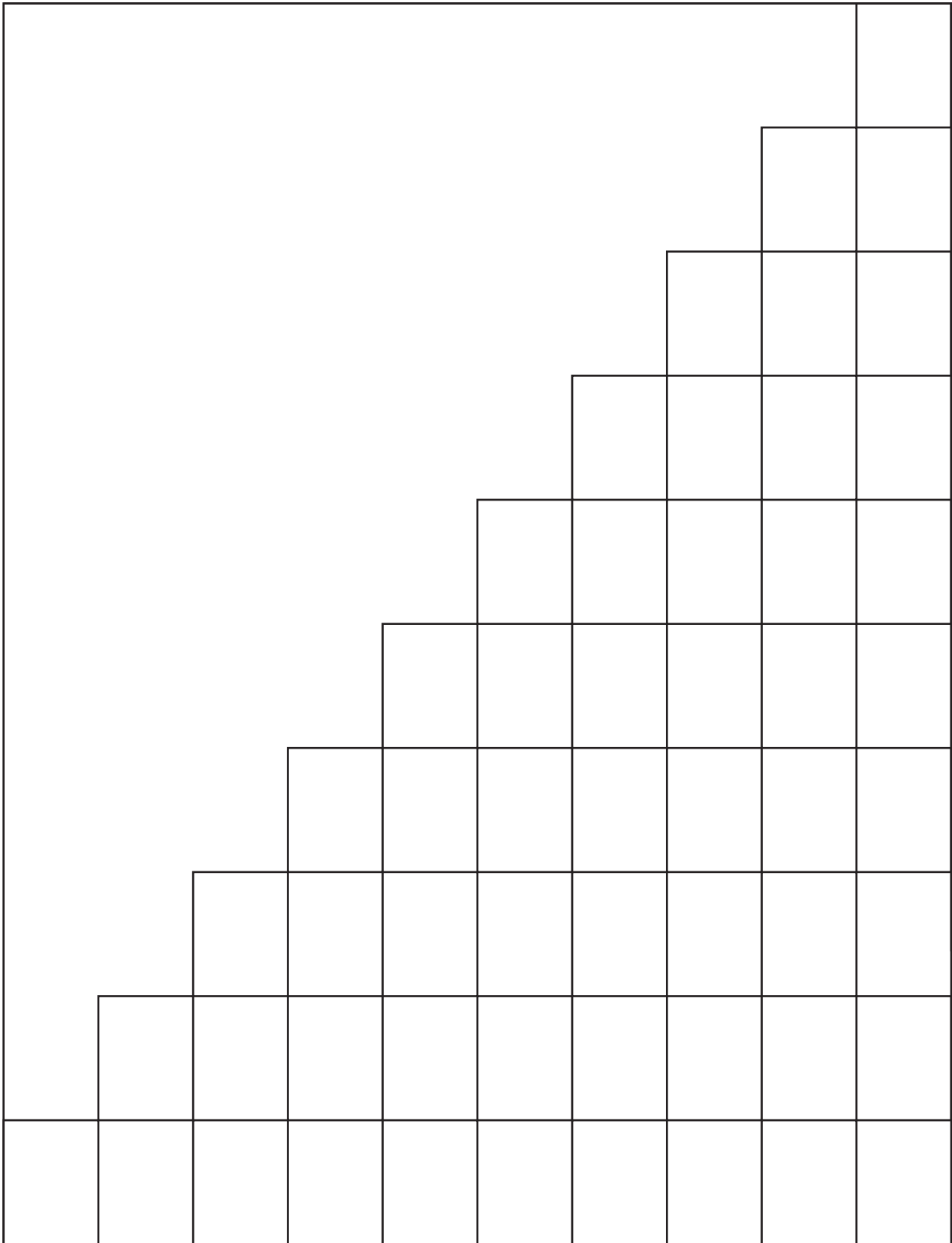

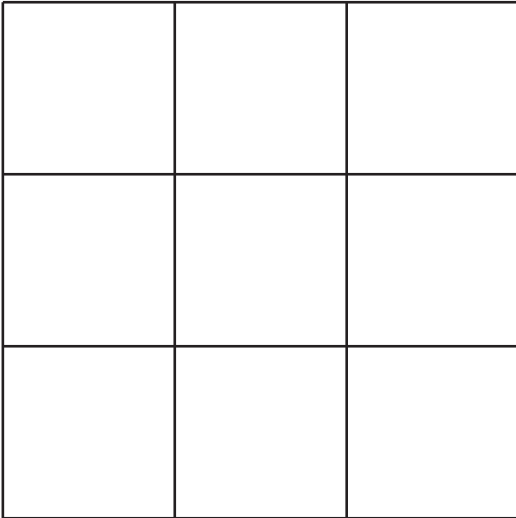
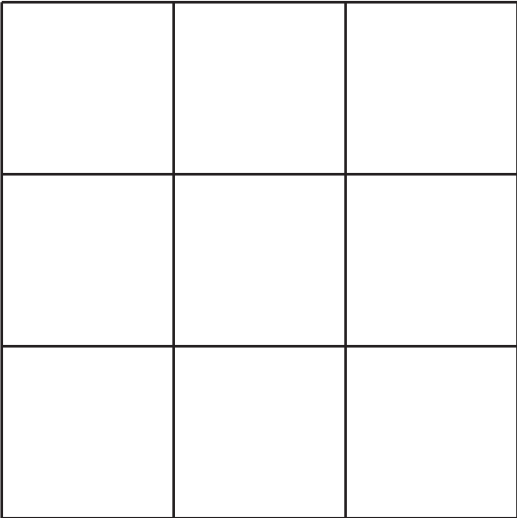
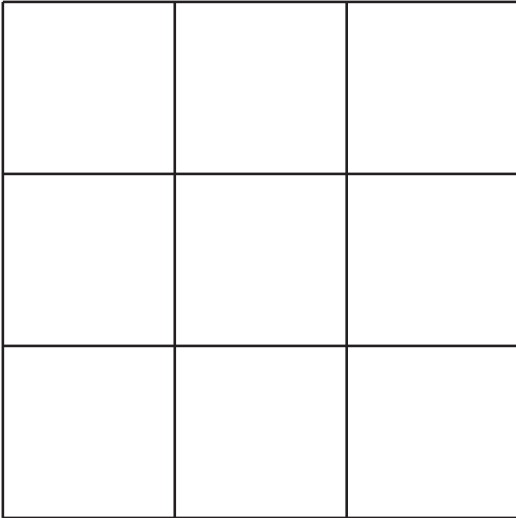
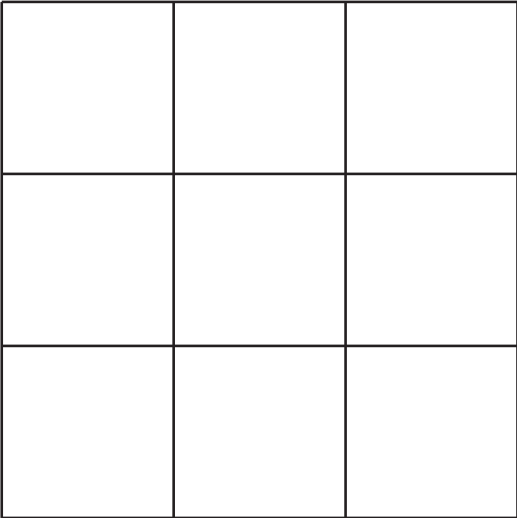

Please feel free to modify this text to make the letter your own

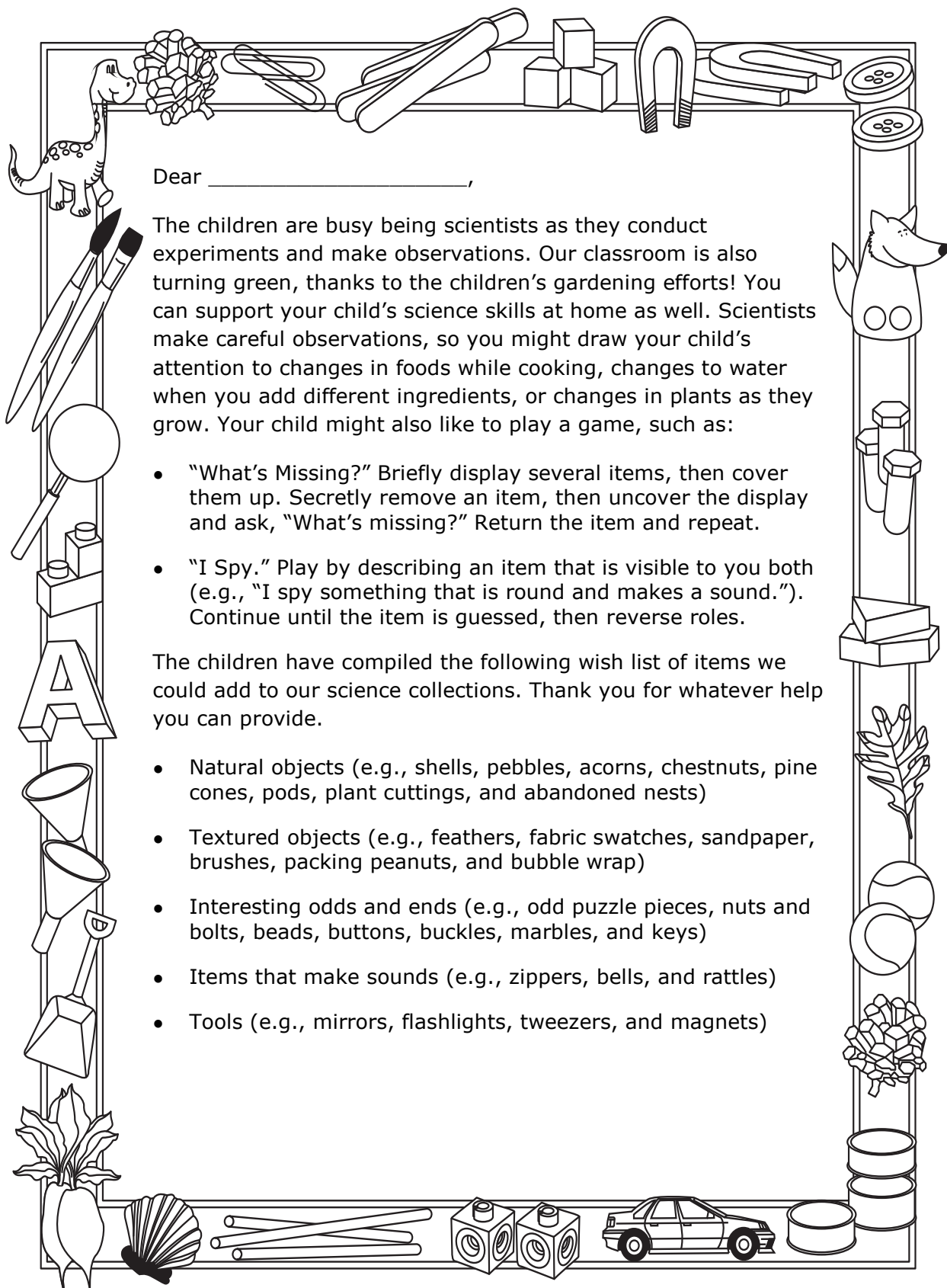

Dear _____,

The children are busy being scientists as they conduct experiments and make observations. Our classroom is also turning green, thanks to the children's gardening efforts! You can support your child's science skills at home as well. Scientists make careful observations, so you might draw your child's attention to changes in foods while cooking, changes to water when you add different ingredients, or changes in plants as they grow. Your child might also like to play a game, such as:

- "What's Missing?" Briefly display several items, then cover them up. Secretly remove an item, then uncover the display and ask, "What's missing?" Return the item and repeat.
- "I Spy." Play by describing an item that is visible to you both (e.g., "I spy something that is round and makes a sound."). Continue until the item is guessed, then reverse roles.

The children have compiled the following wish list of items we could add to our science collections. Thank you for whatever help you can provide.

- Natural objects (e.g., shells, pebbles, acorns, chestnuts, pine cones, pods, plant cuttings, and abandoned nests)
- Textured objects (e.g., feathers, fabric swatches, sandpaper, brushes, packing peanuts, and bubble wrap)
- Interesting odds and ends (e.g., odd puzzle pieces, nuts and bolts, beads, buttons, buckles, marbles, and keys)
- Items that make sounds (e.g., zippers, bells, and rattles)
- Tools (e.g., mirrors, flashlights, tweezers, and magnets)

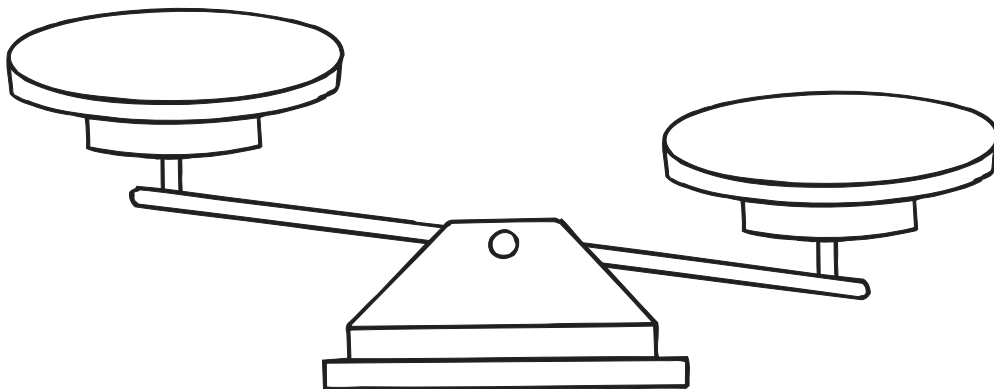
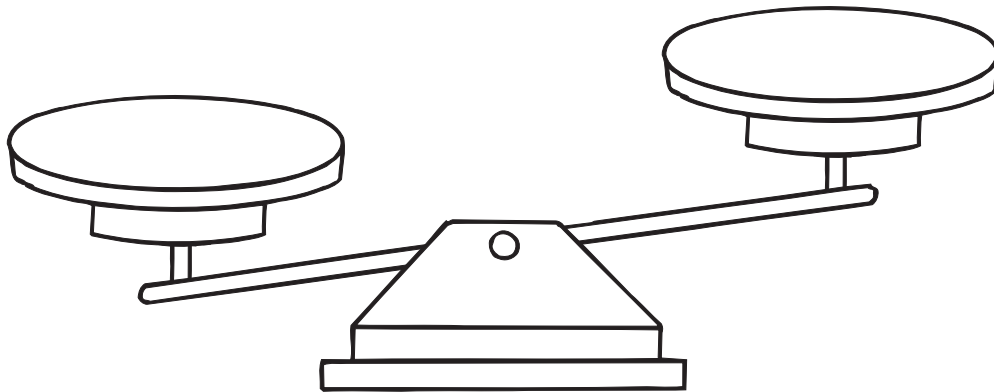
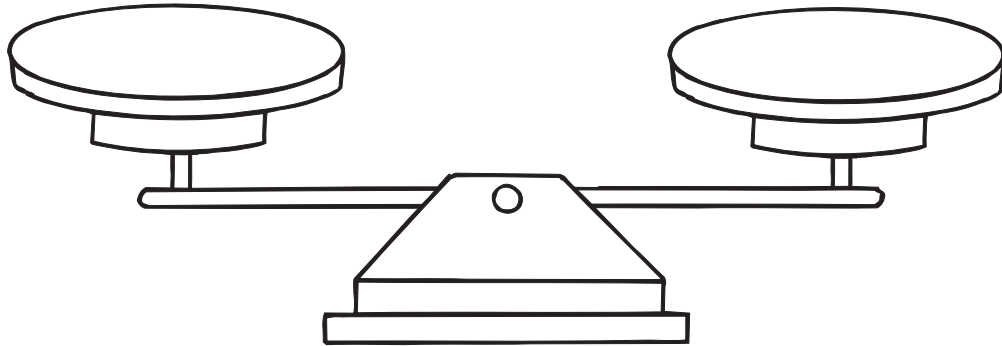

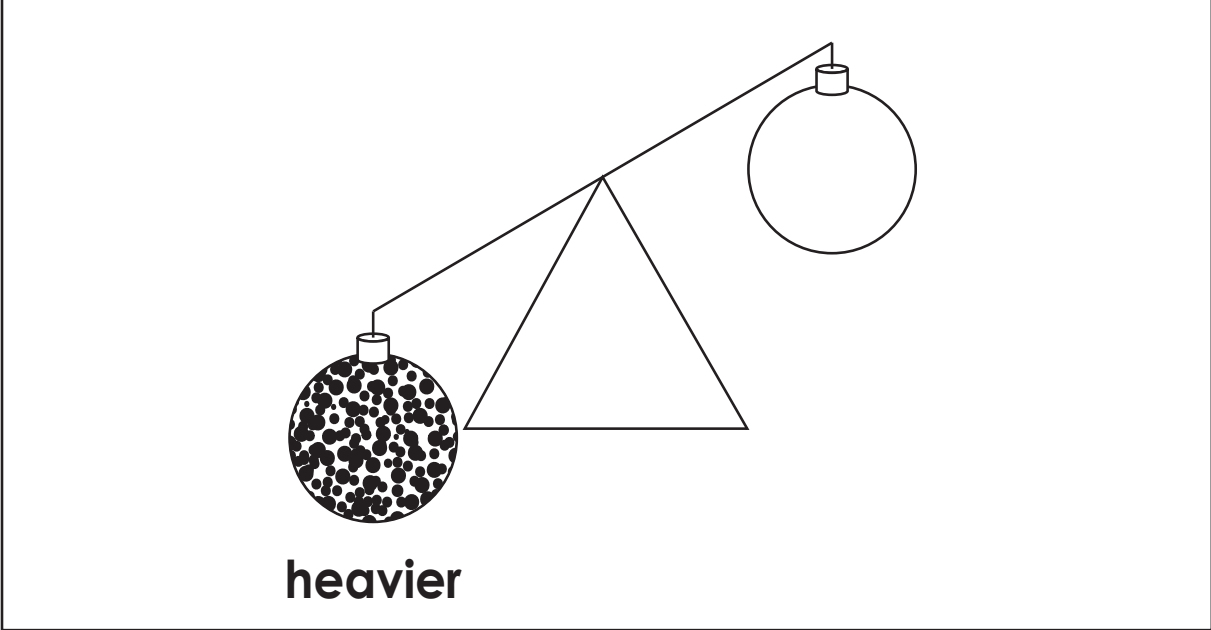
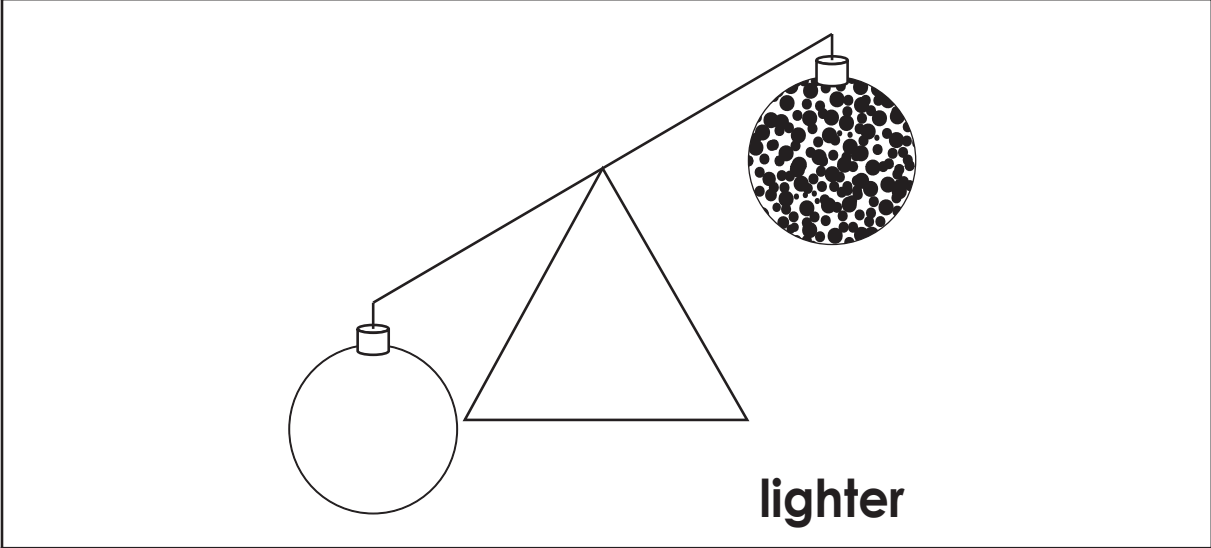
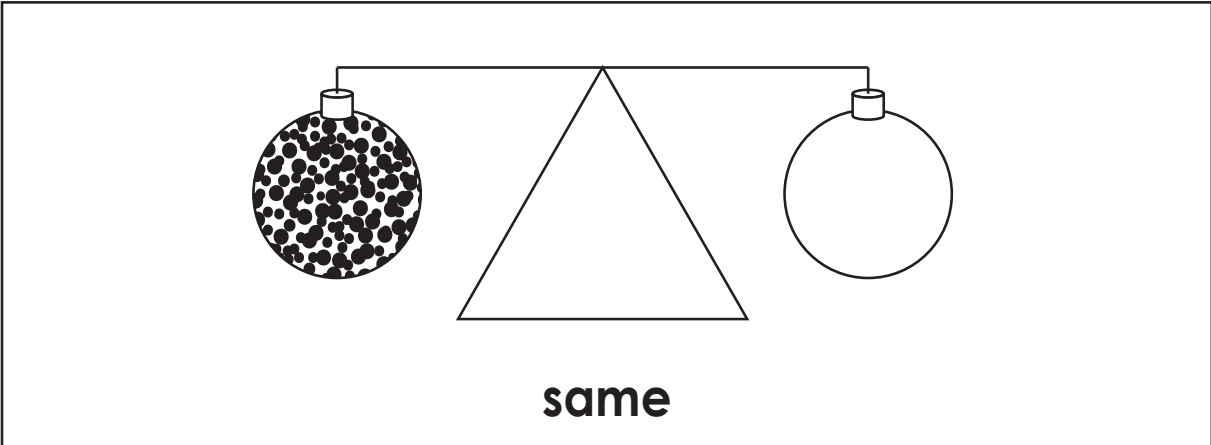

Please feel free to modify this text to make the letter your own.

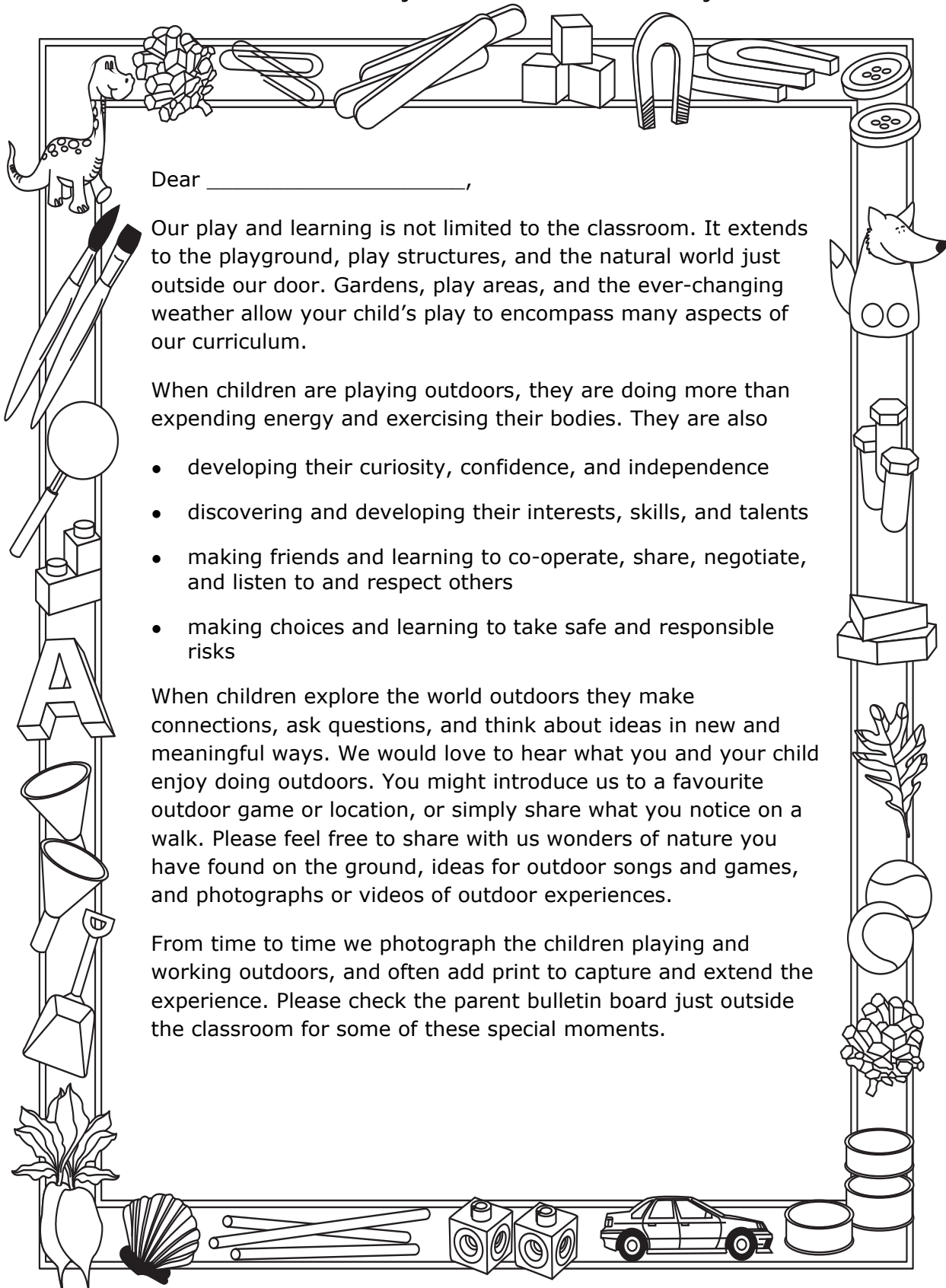

Dear _____,

Our play and learning is not limited to the classroom. It extends to the playground, play structures, and the natural world just outside our door. Gardens, play areas, and the ever-changing weather allow your child's play to encompass many aspects of our curriculum.

When children are playing outdoors, they are doing more than expending energy and exercising their bodies. They are also

- developing their curiosity, confidence, and independence
- discovering and developing their interests, skills, and talents
- making friends and learning to co-operate, share, negotiate, and listen to and respect others
- making choices and learning to take safe and responsible risks

When children explore the world outdoors they make connections, ask questions, and think about ideas in new and meaningful ways. We would love to hear what you and your child enjoy doing outdoors. You might introduce us to a favourite outdoor game or location, or simply share what you notice on a walk. Please feel free to share with us wonders of nature you have found on the ground, ideas for outdoor songs and games, and photographs or videos of outdoor experiences.

From time to time we photograph the children playing and working outdoors, and often add print to capture and extend the experience. Please check the parent bulletin board just outside the classroom for some of these special moments.

Please feel free to modify this text to make the letter your own.

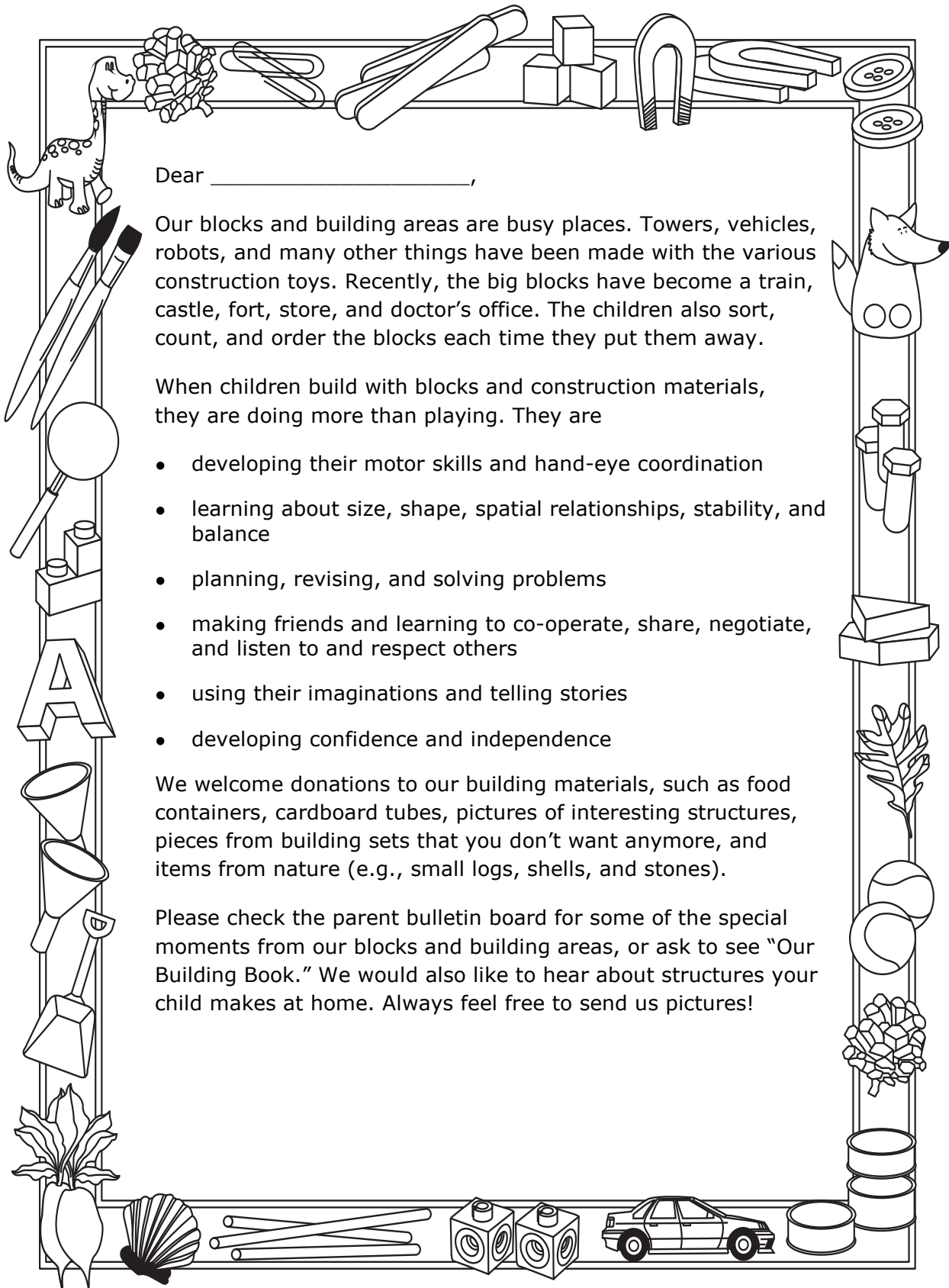

Dear _____,

Our blocks and building areas are busy places. Towers, vehicles, robots, and many other things have been made with the various construction toys. Recently, the big blocks have become a train, castle, fort, store, and doctor's office. The children also sort, count, and order the blocks each time they put them away.

When children build with blocks and construction materials, they are doing more than playing. They are

- developing their motor skills and hand-eye coordination
- learning about size, shape, spatial relationships, stability, and balance
- planning, revising, and solving problems
- making friends and learning to co-operate, share, negotiate, and listen to and respect others
- using their imaginations and telling stories
- developing confidence and independence

We welcome donations to our building materials, such as food containers, cardboard tubes, pictures of interesting structures, pieces from building sets that you don't want anymore, and items from nature (e.g., small logs, shells, and stones).

Please check the parent bulletin board for some of the special moments from our blocks and building areas, or ask to see "Our Building Book." We would also like to hear about structures your child makes at home. Always feel free to send us pictures!

Please feel free to modify this text to make the letter your own.

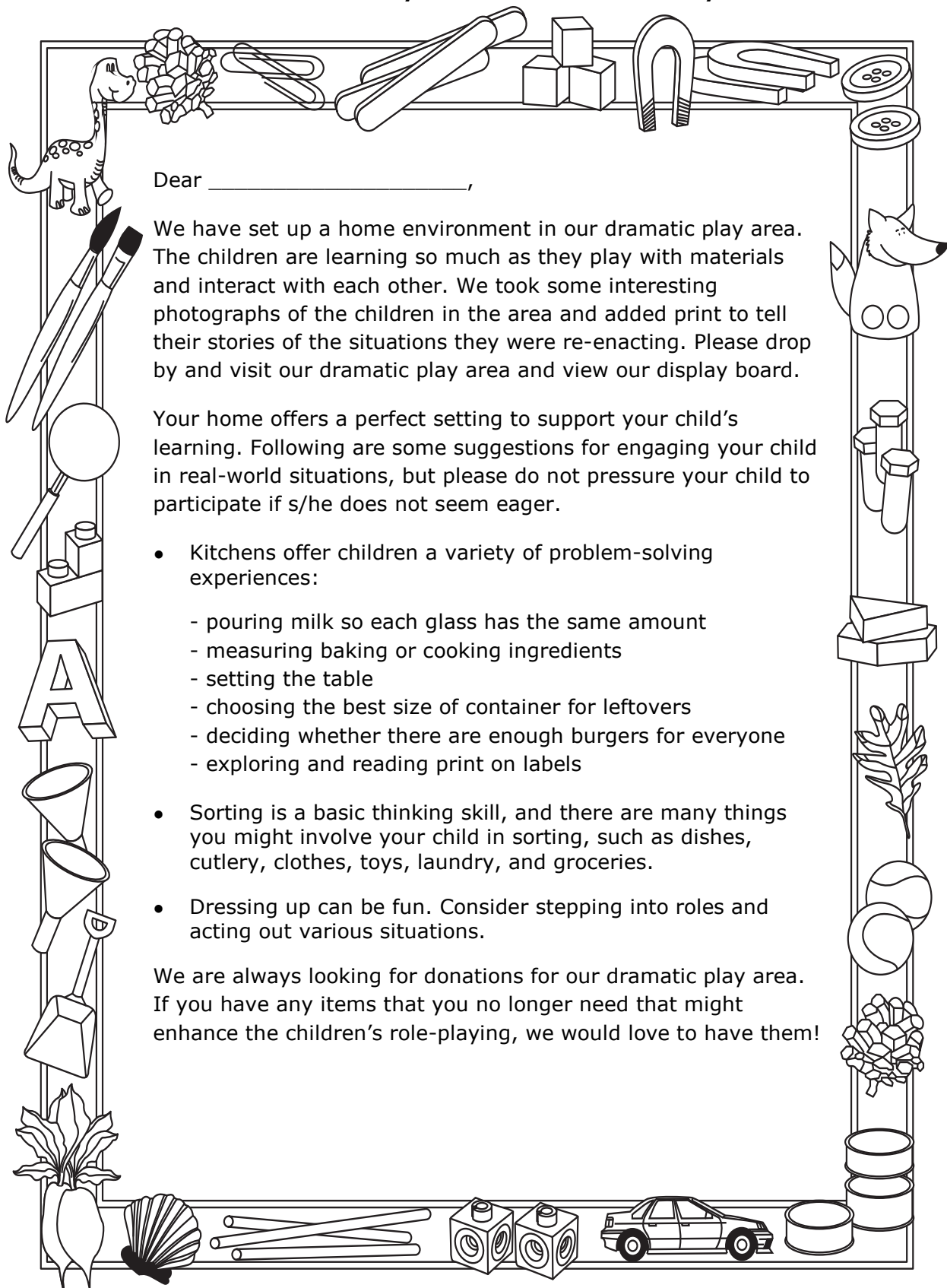

Dear _____,

We have set up a home environment in our dramatic play area. The children are learning so much as they play with materials and interact with each other. We took some interesting photographs of the children in the area and added print to tell their stories of the situations they were re-enacting. Please drop by and visit our dramatic play area and view our display board.

Your home offers a perfect setting to support your child's learning. Following are some suggestions for engaging your child in real-world situations, but please do not pressure your child to participate if s/he does not seem eager.

- Kitchens offer children a variety of problem-solving experiences:
 - pouring milk so each glass has the same amount
 - measuring baking or cooking ingredients
 - setting the table
 - choosing the best size of container for leftovers
 - deciding whether there are enough burgers for everyone
 - exploring and reading print on labels
- Sorting is a basic thinking skill, and there are many things you might involve your child in sorting, such as dishes, cutlery, clothes, toys, laundry, and groceries.
- Dressing up can be fun. Consider stepping into roles and acting out various situations.

We are always looking for donations for our dramatic play area. If you have any items that you no longer need that might enhance the children's role-playing, we would love to have them!

Canadian Coin Cut-outs

Line Master 56

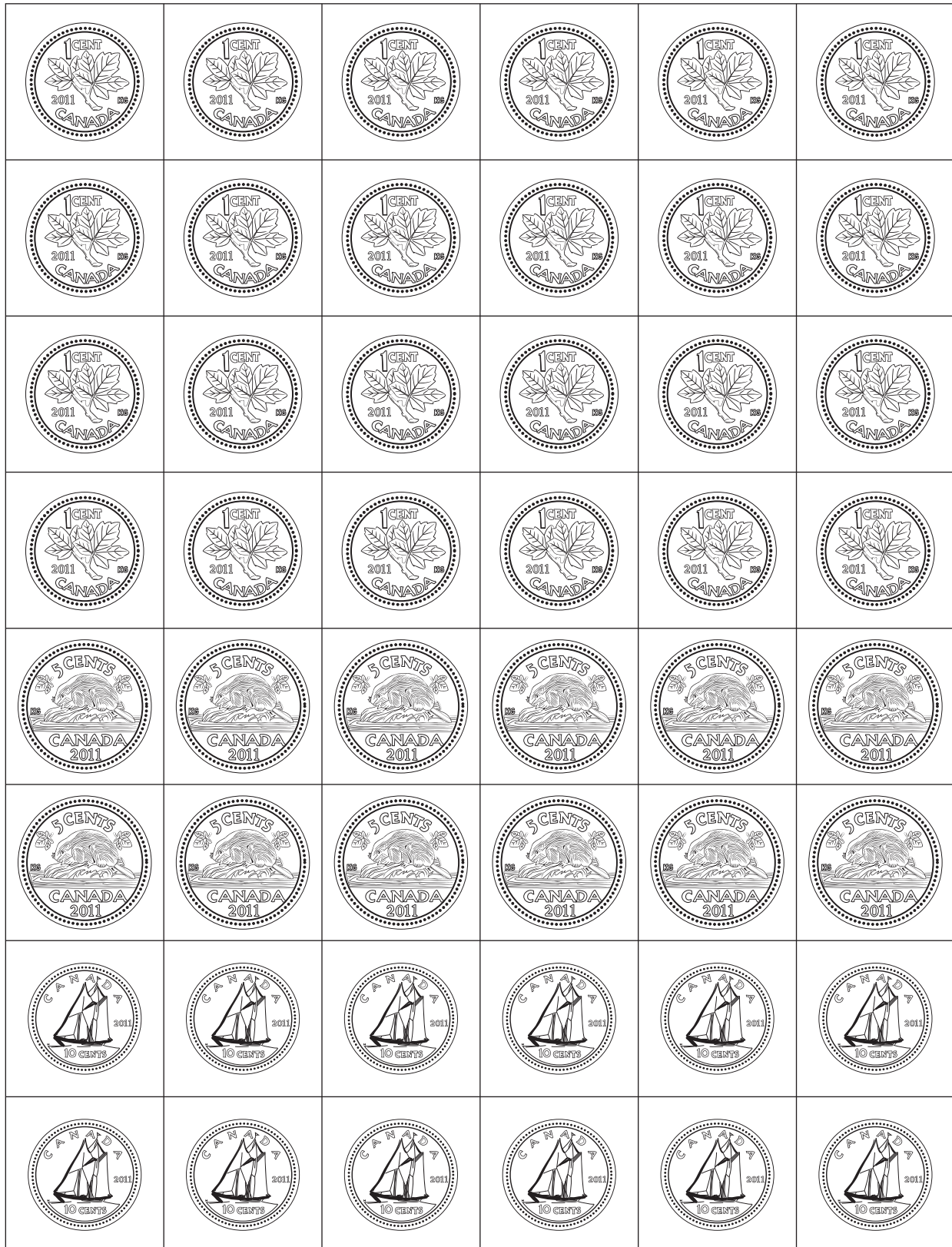

Coin image © 2011 Royal Canadian Mint – All Rights Reserved / Image de pièce © 2011 Monnaie royale canadienne – Tous droits réservés

Line Master 56, *Explorations*. The right to reproduce or modify this page is restricted to purchasing schools. This page may have been modified from its original. Copyright © 2012 Pearson Canada Inc.

1.

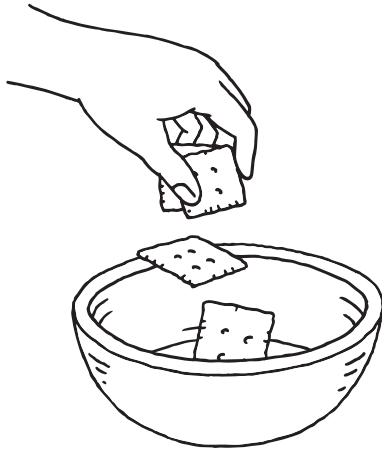

Add 4 crackers.

2.

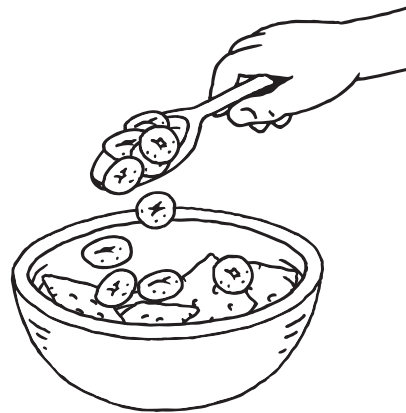

Add cereal.

3.



Add 5 raisins.

4.



Add 6 banana chips.

5.



Mix well.

1.



Chop
2 apple slices.

2.

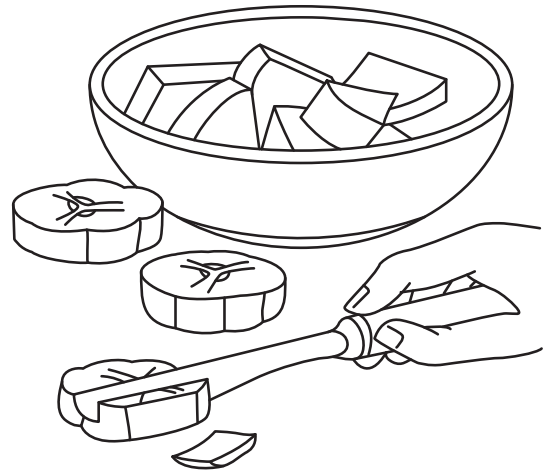

Chop
3 banana slices.

3.

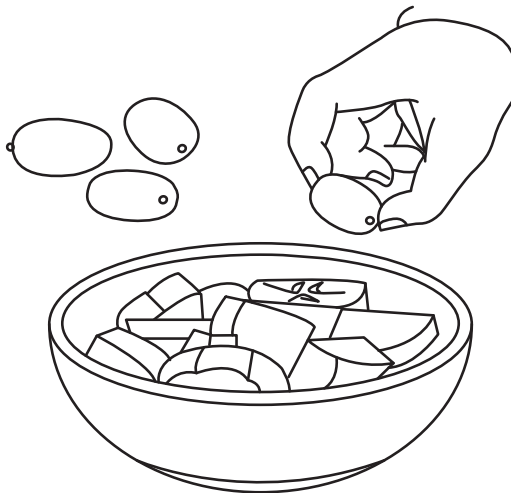

Add
4 grapes.

4.



Add
1  yogurt.

Please feel free to modify this text to make the letter your own.

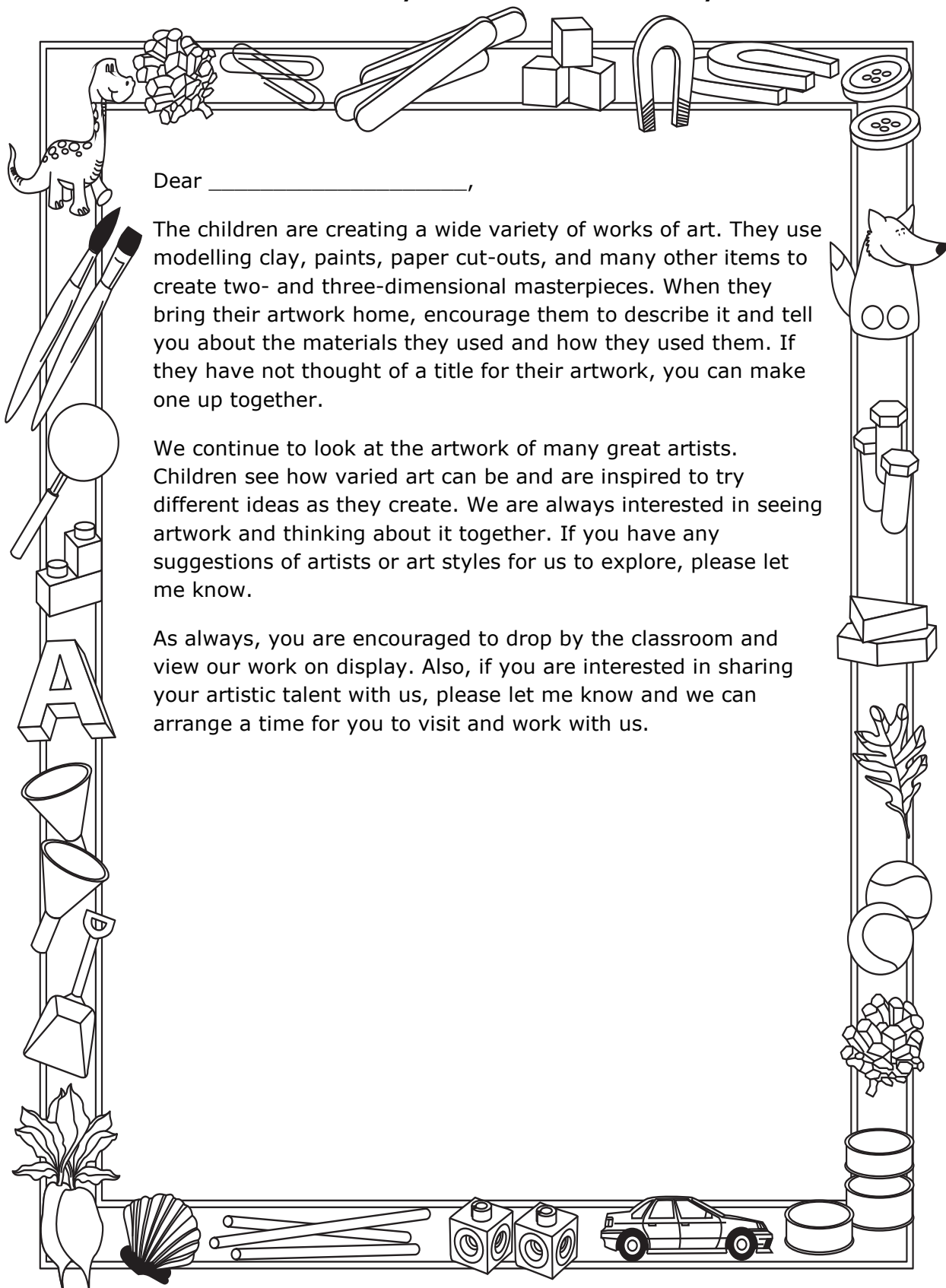

Dear _____,

The children are creating a wide variety of works of art. They use modelling clay, paints, paper cut-outs, and many other items to create two- and three-dimensional masterpieces. When they bring their artwork home, encourage them to describe it and tell you about the materials they used and how they used them. If they have not thought of a title for their artwork, you can make one up together.

We continue to look at the artwork of many great artists. Children see how varied art can be and are inspired to try different ideas as they create. We are always interested in seeing artwork and thinking about it together. If you have any suggestions of artists or art styles for us to explore, please let me know.

As always, you are encouraged to drop by the classroom and view our work on display. Also, if you are interested in sharing your artistic talent with us, please let me know and we can arrange a time for you to visit and work with us.

Please feel free to modify this text to make the letter your own.

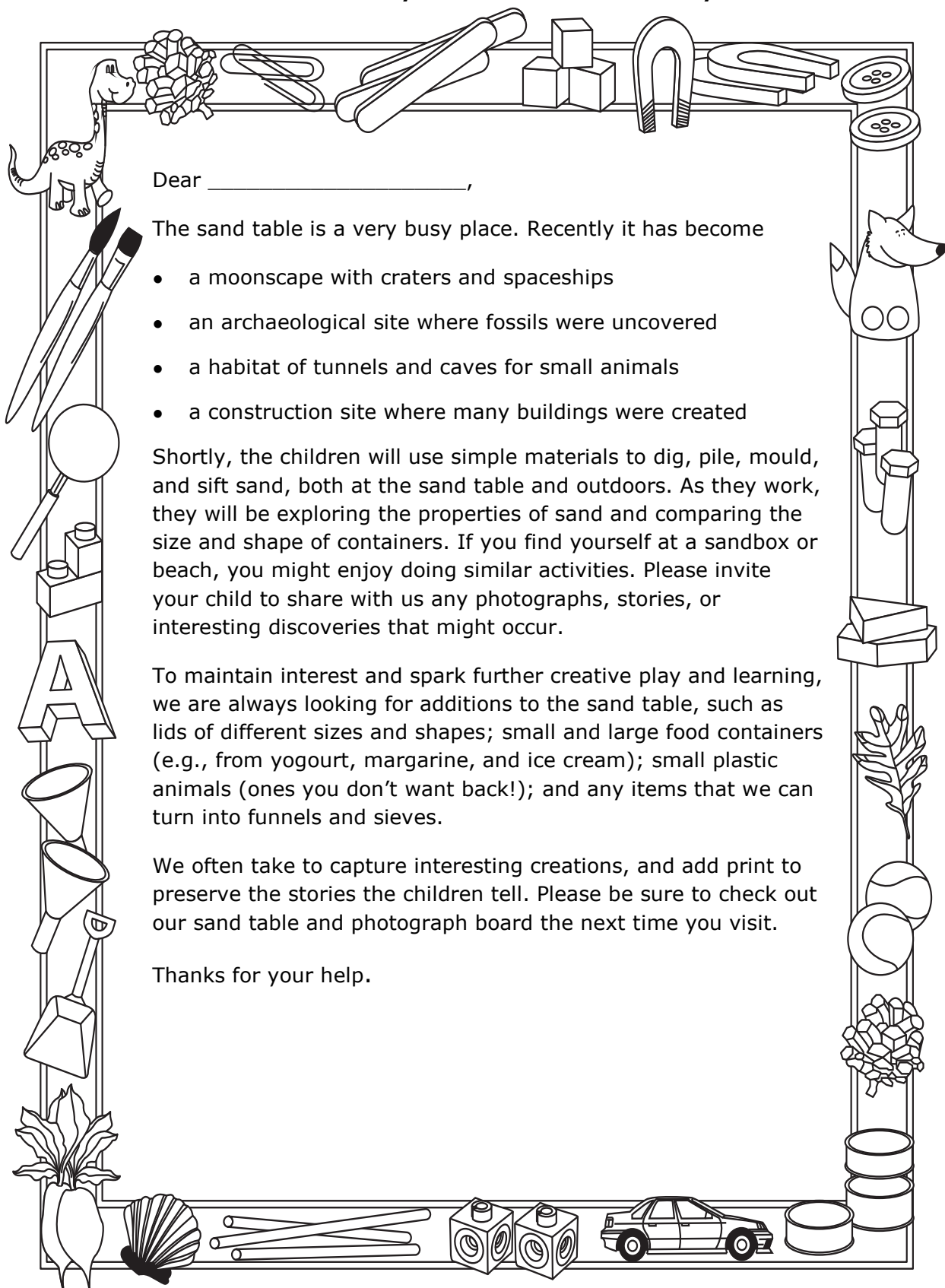

Dear _____,

The sand table is a very busy place. Recently it has become

- a moonscape with craters and spaceships
- an archaeological site where fossils were uncovered
- a habitat of tunnels and caves for small animals
- a construction site where many buildings were created

Shortly, the children will use simple materials to dig, pile, mould, and sift sand, both at the sand table and outdoors. As they work, they will be exploring the properties of sand and comparing the size and shape of containers. If you find yourself at a sandbox or beach, you might enjoy doing similar activities. Please invite your child to share with us any photographs, stories, or interesting discoveries that might occur.

To maintain interest and spark further creative play and learning, we are always looking for additions to the sand table, such as lids of different sizes and shapes; small and large food containers (e.g., from yogourt, margarine, and ice cream); small plastic animals (ones you don't want back!); and any items that we can turn into funnels and sieves.

We often take to capture interesting creations, and add print to preserve the stories the children tell. Please be sure to check out our sand table and photograph board the next time you visit.

Thanks for your help.

Please feel free to modify this text to make the letter your own.

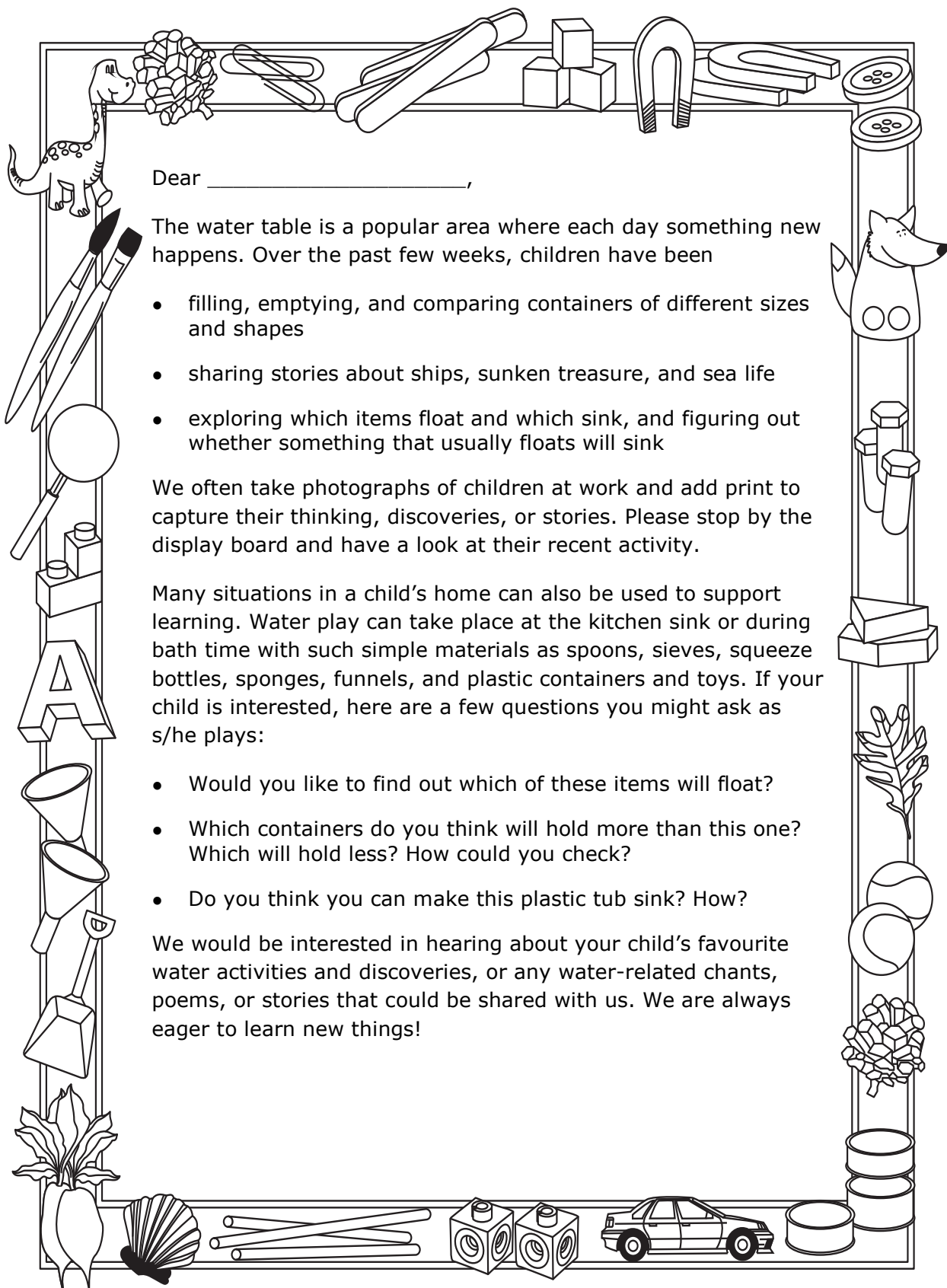

Dear _____,

The water table is a popular area where each day something new happens. Over the past few weeks, children have been

- filling, emptying, and comparing containers of different sizes and shapes
- sharing stories about ships, sunken treasure, and sea life
- exploring which items float and which sink, and figuring out whether something that usually floats will sink

We often take photographs of children at work and add print to capture their thinking, discoveries, or stories. Please stop by the display board and have a look at their recent activity.

Many situations in a child's home can also be used to support learning. Water play can take place at the kitchen sink or during bath time with such simple materials as spoons, sieves, squeeze bottles, sponges, funnels, and plastic containers and toys. If your child is interested, here are a few questions you might ask as s/he plays:

- Would you like to find out which of these items will float?
- Which containers do you think will hold more than this one? Which will hold less? How could you check?
- Do you think you can make this plastic tub sink? How?

We would be interested in hearing about your child's favourite water activities and discoveries, or any water-related chants, poems, or stories that could be shared with us. We are always eager to learn new things!